

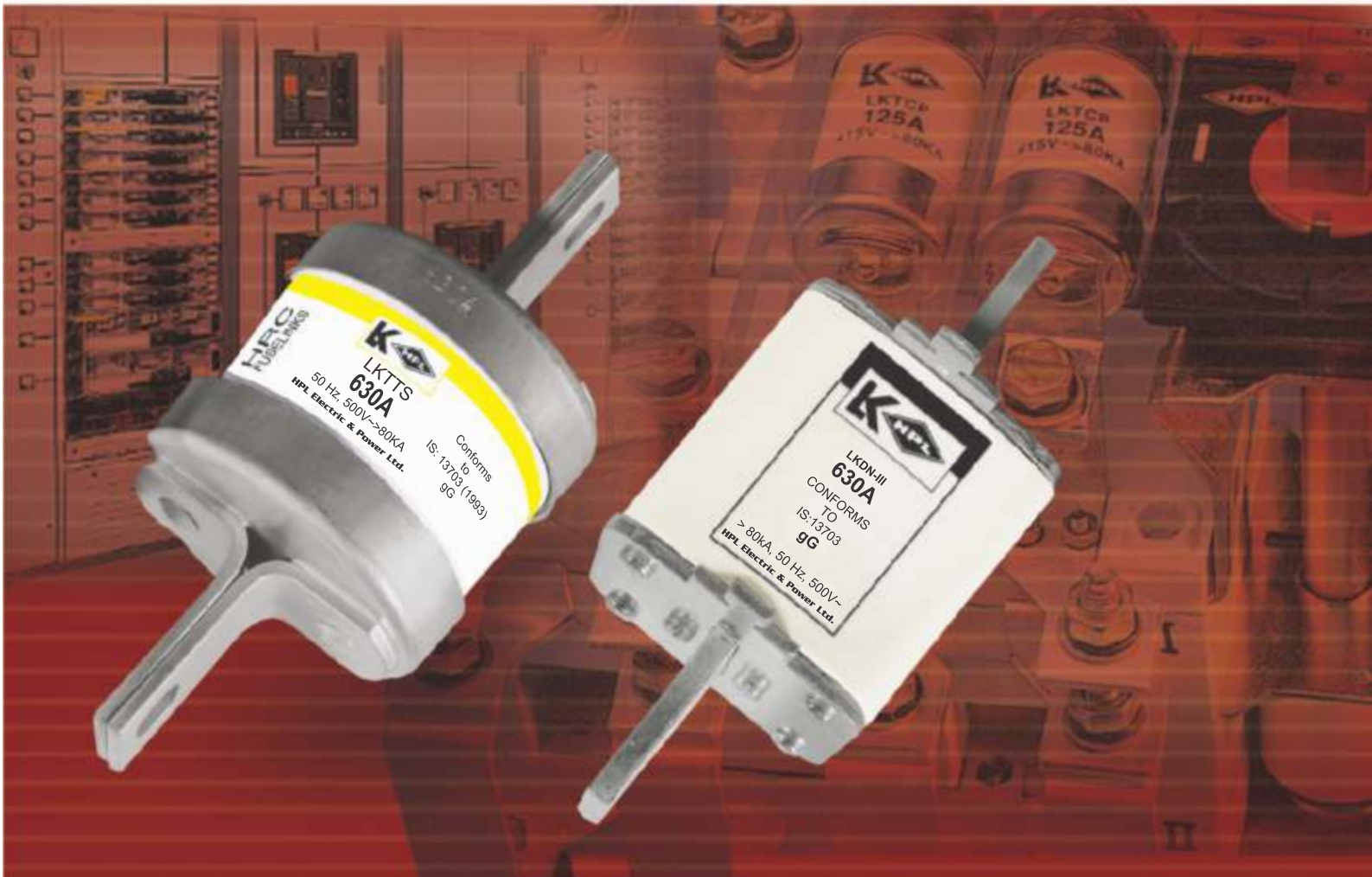

HRC Fuse Links DIN / Bolted Type Contacts



- Range : 2 Amps to 630 Amps
- Breaking capacity >80kA, 500V, 50Hz Ac
- Conforms to Indian & International Standard IS:13703 (1993) & IEC:269-1986
- Tested at CPRI
- Low watt loss



ISO-9001:2008
Certified Company

The Symbol of Protection



HRC Fuse Links - LKDN

Knife Contacts (DIN Type)

LK-HPL Type LKDN HRC (High Rupturing Capacity) Fuse Links with Knife Contacts are ideal for the perfect protection of low voltage circuits for Industrial and general application such as cables, flexible cords and other equipments, against over loads and short circuit faults. Fuse elements are accurately shaped & designed for consistency & reliability. Quartz Silica Sand is used as filler material inside the fuse as arc quenching / heat absorbing medium.

- Range** LKDN Fuse links are 6 Amp to 630 Amp in five different sizes with beaking capacity of more than 80kA at 500 Volt 50 Hz, AC.
- Reference Standards** LKDN Fuse links comply with Indian & International Standards, i.e. IS: 13703 (1993) & IEC-269 (1986).
- Power Loss** LKDN Fuse links are designed for very low power loss for cool running and energy saving in power installations.
- Protection** LKDN Fuse links give a close protection, even during over load and capacitive circuits.
- Characteristics** LKDN Fuse links operate within very close band to the time-current values given in standard IS: 13703 (1993) with very low let through energy & cutt off current at short circuit.
- Indication** LKDN Fuse links incorporate a flap indicator which can be used for remote signalling when fitted with a striker and auxiliary switch.
- Certification** LKDN Fuse links are fully tested and certified by CPRI. LKDN Fuse links are certified by BIS to IS: 13703 (1993).



Knife Contact Range

6Amps - 630Amps

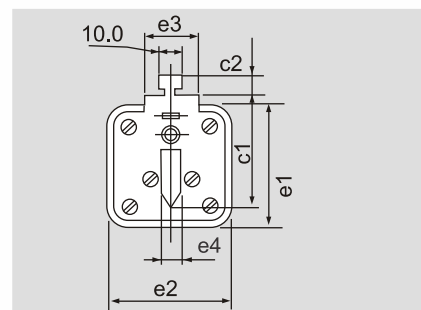
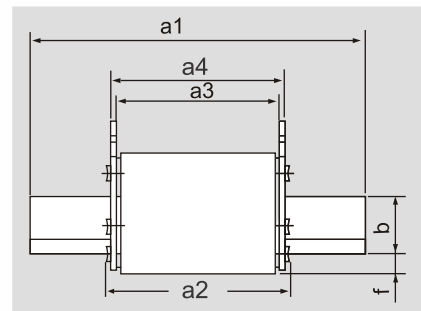

Range

Size	Type	Current Rating In Amps.
000	LKDN-000	6, 10, 16, 20, 25, 32, 50, 63, 80, 100A
00	LKDN-00	6, 10, 16, 20, 25, 32, 50, 63, 80, 100, 125, 160A
1	LKDN-I	32, 50, 63, 80, 100, 125, 160, 200, 250A
2	LKDN-II	200, 250, 315, 400A
3	LKDN-III	315, 400, 425, 500, 630 A

Dimensional Details

SIZE	TYPE	a1	a2	a3	a4	b	c1	c2	e1	e2	e3	e4	f
000	LKDN-000	78	53	46	50	15	35.5	9.5	40	21	-	6	6
00	LKDN-00	80	50.5	46	50	15	35	9.5	43	29.5	20	6	13
1	LKDN-I	133	70	60	66	20.5	40	9	46	46	22	6	10
2	LKDN-II	149	70	60	66	26	47.5	10	57	57	22	6	11.5
3	LKDN-III	151	72	62	68	33	60	10.5	73	73	22	6	16.5



HRC Fuse Links - LKTS

Bolted Type (BS Type)

LK-HPL Bolted type LKTS HRC (High rupturing capacity) fuselinks are manufactured using precision assembly methods to ensure peak performance for protection of low and medium voltage circuits against overload and short circuit faults. Fuse elements are accurately shaped and designed for consistency and reliability. Quartz Silica Sand is used as filler material inside the fuse as arc quenching / heat absorbing medium.

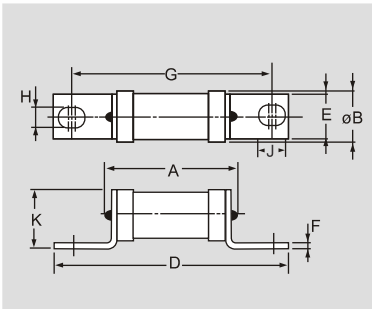
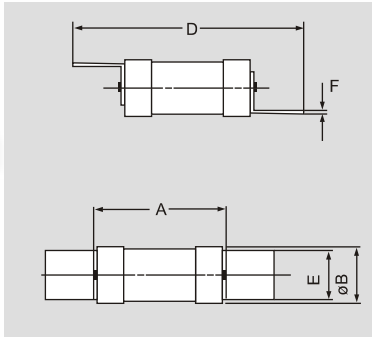

Bolted Type Range

2 Amps - 630 Amps

- Range** LKTS Fuse links are 2 Amps to 630 Amps with breaking capacity of more than 80KA at 500V AC, 50 Hz.
- Reference Standards** LKTS Fuse links comply with Indian & International Standards i.e. IS: 13703 (1993) and IEC-269 (1986)
- Power Loss** LKTS Fuse links are designed for very low power loss for cool running and energy saving in power installations.
- Protection** LKTS Fuse links give a close protection during overload and short circuit
- Characteristics** LKTS Fuse links conform within very close band to the time current values given in IS:13703 (1993) & IEC-269 (1986). The Fuse links are not sensitive to normal electro magnetic disturbances generated by the Fuse links themselves. The barrels are extruded under vacuum to prevent the occurrence of air pockets. The fuse links give satisfactory performance under both long term cyclic overload conditions and repeated transient overload such as motor starting surges or inrush current transformers or capacitors.

Off-Set Tags:

S. No.	Fuse Type	Rating In Amps	A	øB	D	E	F
1	LKNS	2,4,6,10,16, 20,25,32	35	14	60	11	0.85

Off-Set Tags 2-Hole Fixing

Fuse Type	Rating in Amps	A	øB	D	E	F	G	H	J	K
LKTSA	6,10,16,20,25,32	36	14	85.5	9	1.25	73	5.5	7.5	15.2
LKTSS	35,40, 50, 63	57	22.5	86	13	1.25	73	5.2	11.25	25
LKTSD	80,100,125, 160	50	23	111	19	2.4	94	8.5	11.2	25.5
LKTSFP	125,160,200	61	35	112	19	2.4	94	8.5	12	36.6
LKTCP	80,100,125	66	32.5	110	19	2.4	94	8.4	10	34

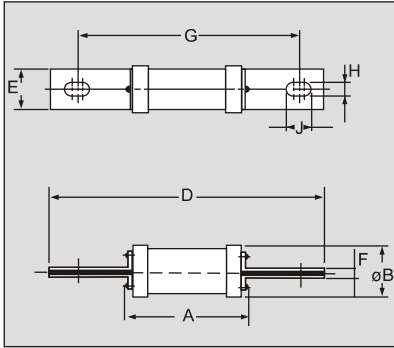

Central Tags 2-Hole Fixing:

Fuse Type	Rating in Amps	A	øB	D	E	F	G	H	J
LKTSDC	80,100, 125, 160	58.5	23	133	19	3.2	111	8.7	11.2
LKTSM	125,160,200	58.5	34.5	133	19	3.2	111	8.7	11.2
LKTSM	250,300,315	60	40.5	133	25	3.2	111	8.7	11.2
LKTSM	355,400	63	53.5	136	25.5	4.8	111	9	13

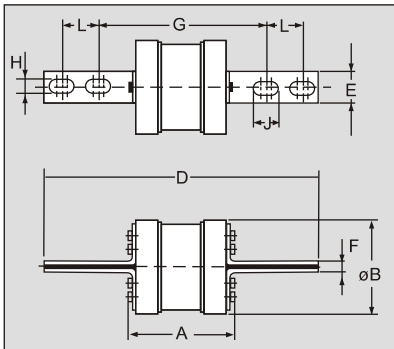

Central Tags 4-Hole Fixing:

Fuse Type	Rating in Amps	A	øB	D	E	F	G	H	J	L
LKTTS	400,450,500,550,630	83	75.0	160	25.5	6.4	133	11	15.8	-
LKTSM	400,450,500,550,630	85	75.5	212	25.5	6.4	133	11	15.8	25.4

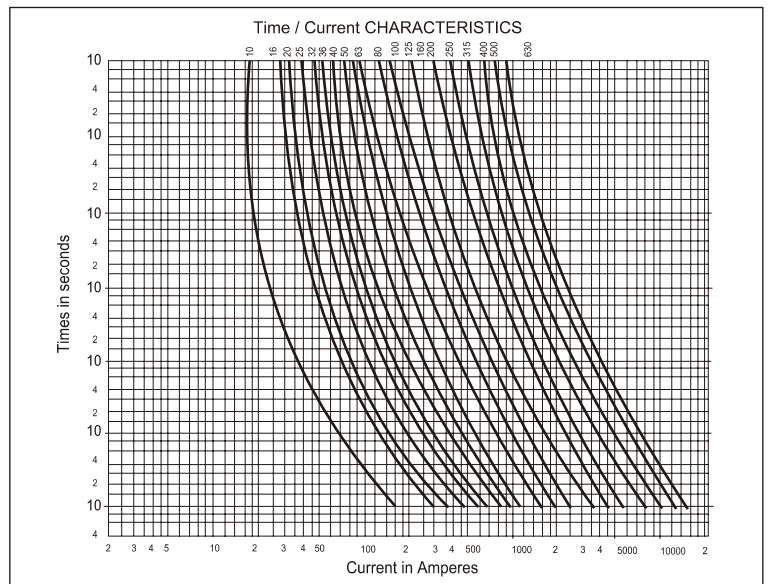
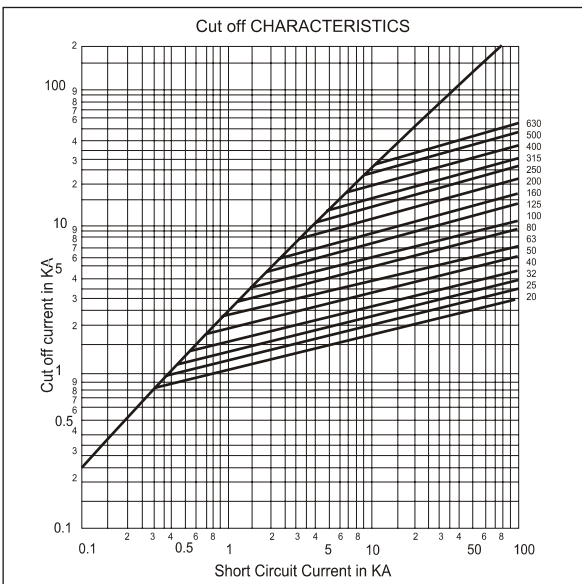

HPL-HRC0118



HPL Electric & Power Ltd

Corp. Office : Windsor Business Park, B-1D, Sector-10,
Noida, U.P. - 201301, INDIA.
Tel.: +91-120-4656300, Fax: +91-120-4656333
Registered Office : 1/21, Asaf Ali Road, New Delhi - 110 002, INDIA.
E-mail : hpl@hplindia.com; enquiry@hplindia.com

**Customer Care No. :
18004190198**

www.hplindia.com