



AV On Load Changeover Switches from 63A to 3150A



3 *Triple* Safety
HPL

- Arc Chute
- Terminal Shroud
- Phase Separator



HIGHLIGHTS

- » Conforms to IS/IEC:60947-3
- » Available in 6 frame sizes... rated current from 63A to 3150A
- » Compact Design
- » Quick Make & Quick Break mechanism (spring loaded contact)
- » Clear indication of 'ON', 'OFF' and 'ON' Position (I-O-II)
- » High Mechanical & Electrical life
- » Arc chute plates to enhance contact life
- » 100% Neutral rating... true 4 pole switch
- » Line load reversibility
- » Vertical or lateral mounting
- » Suitable for both aluminum & copper termination
- » Total safety : All moving and live parts covered
- » Terminal cover, source separator, phase barrier as standard feature
- » ROHS Compliant
- » Wide range of accessories

Application

The HPL make Onload Changeover Switch is 4 Pole manually operated, consisting of two sets of terminals for connecting to two incoming supply sources. It ensures safe changeover from one source to another and is suitable for use in individual enclosures, switch boards, lighting and power panels etc. with following features:-

- Suitable for incoming and outgoing feeders
- 3 stable positions (I – O – II)
- Fully visualized breaking
- Bridging bars mounted on all ratings as standard feature
- Pre equipped terminal cover, source separator, phase barrier with all ratings
- Compact design - saves panel space / supports easy maintenance
- Quick Make & Break type irrespective of human torque
- Resistant to Tropical conditions & polluted environment
- High thermal & dynamic withstand capacity
- Self extinguishing fiberglass re-inforced insulating body
- Available in Open execution, Steel sheet Enclosure & Direct Mounted type
- AC 23 A Category
- Bounce free contacts
- Any pole can be used as Neutral pole... true 4 pole switch
- Unique Safety Handle with built in door padlock facility
- 3 lock pad lock, lockable in ON & OFF positions
- Castle lock, interlocking schemes with MCCB/ACB
- High Electrical & Mechanical life

Approvals & Test

- Time tested
- Customer Accepted
- CPRI Tested
- ISO 9001 Certified



Globally Accepted
exporting to over
25 countries





On Load Changeover Switches



Advantages



Compactness

It is very compact in size and hence helps in saving space in the enclosures, panels etc. Due to its slim size uses the distribution space very efficiently regardless of fact whether it is in residential or funtional buildings.



Simplicity

Its handling is easy and simple. Its simplicity and ease in use allows the user for quick installation. Any pole can be used as Neutral pole. Line load reversibility supports user in comer and out going design. Plugin auxiliary contact kit easy to mount on the switch. Grove to insert safety shield



Total Safety

Total Safety

Its is very safe to use. all moving parts and live parts are covered eliminating possibilities of casualties & electric shocks. The insulation property of the material used is highly reliable, self extinguishing with high insulating properties and remains intact in even critical conditions. arch chute chamber evades fire in surges

Isolation Function:

These Onload changeover switches are **Suitable for Isolation** as per IS/IEC 60947-3. Isolation function highlights the following points:-

- Position of main contact is indicated clearly by a separate mechanical indicator.
- No residual current



**Positive isolation
no room for surges**



On Load Changeover Switches



Compact Design Total Safety



Shrouded

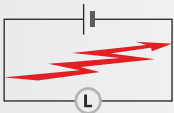

Prevents Shorting between 2 Sources



Moving Parts Sharp Edges Covered

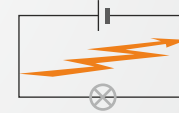

Prevents Shorting between 2 phase



Total Safety

- Source Cover, Terminal Shroud & Phase barrier as standard design product
- Enclosed operating rod
- Self extinguishing fiberglass re-inforced insulating body
- 3 lock pad lockable handle in both ON & OFF positions



Self Fire Extinguishing

- High thermal and dynamic withstand capacity with self extinguishing fibreglass insulating body

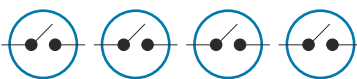

Positive Isolation

- Fully visualised breaking
- Emergency breaking
- safe isolation of downstream loads for maintenance



Load Line Reversibility

- Quick make quick break
- All poles rated 100%
- In coming and outgoing easily interchangeable at site

Working Principle:

Stationary contacts for R, Y, B, N Phase are fixed to the moulded housing. 4 sets of moving contacts housed in a carrier are moved towards right for ON or left for OFF. The moving contacts slide on to the stationary contacts to make the circuit.

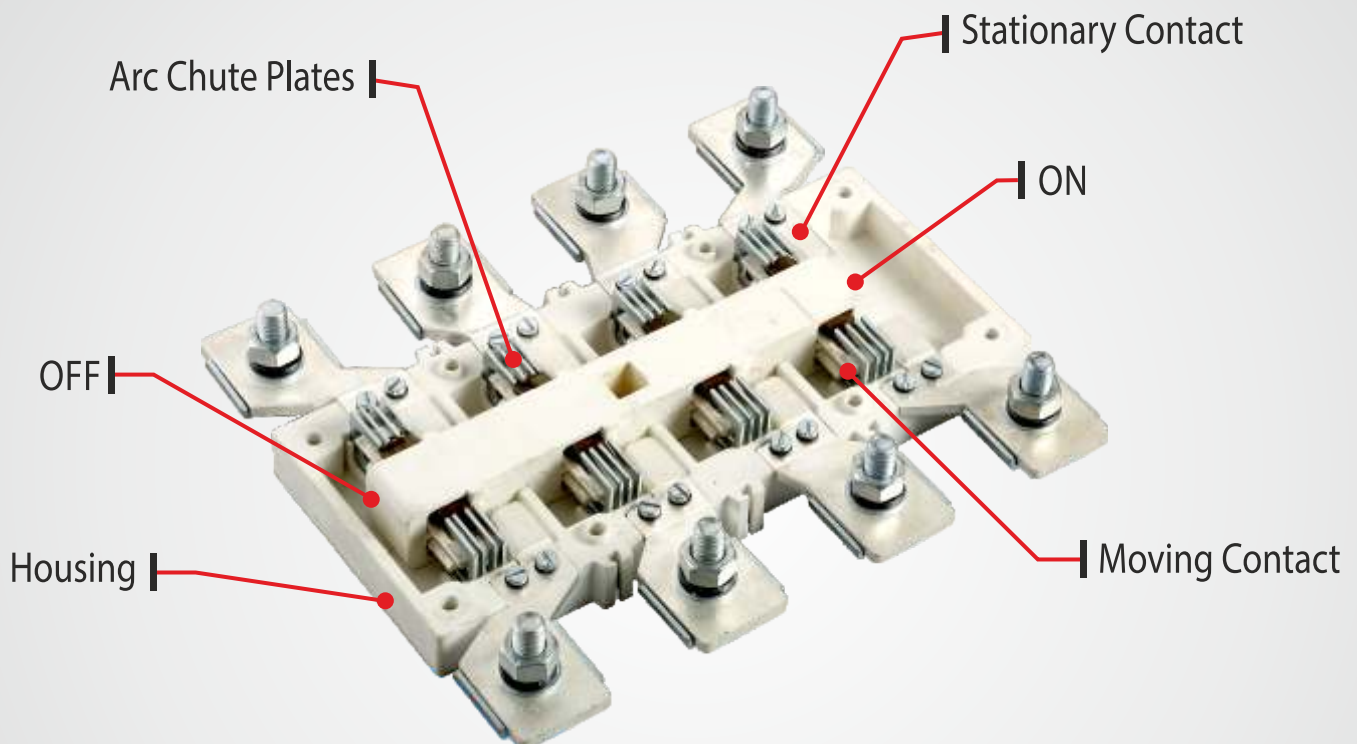

The Technology for Onload Changeover Switch

1. Arc Chamber

The Arc Chamber is specially designed and provided with arc chute plates with an arc channel as a flow guide to reduce the arc length, thereby improving the capability of extinguishing the arc. This enhances the life of the moving & stationary contacts thereby increasing the life of the product.

2. Body

Body parts are made of superior quality of thermoset plastics to withstand the stringent short circuit conditions where it has to see very high thermodynamic stresses. Its high insulation strength avoids any damage to the product.



Overview (Operations)

Direct

The pad lockable handle is mounted directly on the Onload Changeover switch and is lockable in both OFF & ON positions.

External

The pad lockable handle is mounted on the panel door and lockable in both OFF & ON positions. The external front operation ensures that the door is locked in ON position.

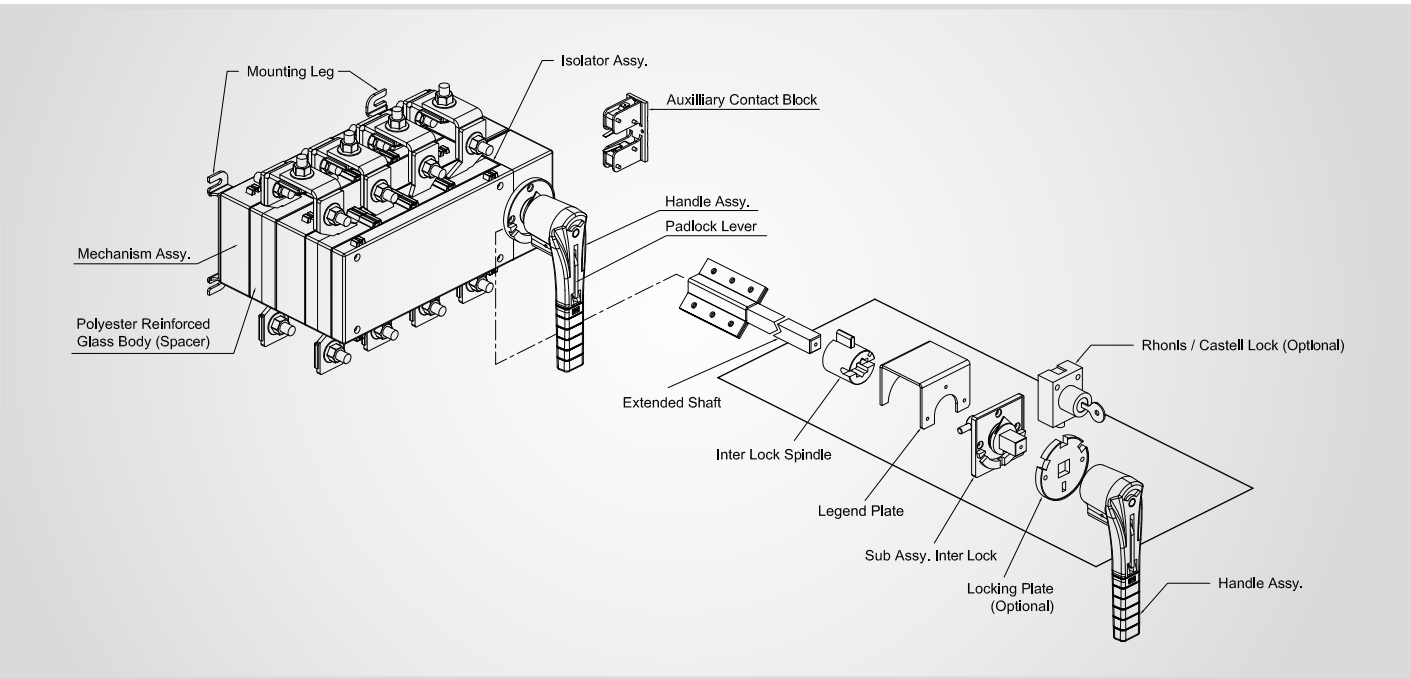

Accessories

Handle

The Changeover switch has a single hand operated handle upto 630A & two hand operated handle for ratings 800A Amps and above. The handle offers the following features:

- Provision for providing 3 padlocks in both OFF & ON Positions.
- Telescopic operating shaft for varied depth adjustment.

Handle up to 630A



Handle with padlock lever

Handle for 800A and above

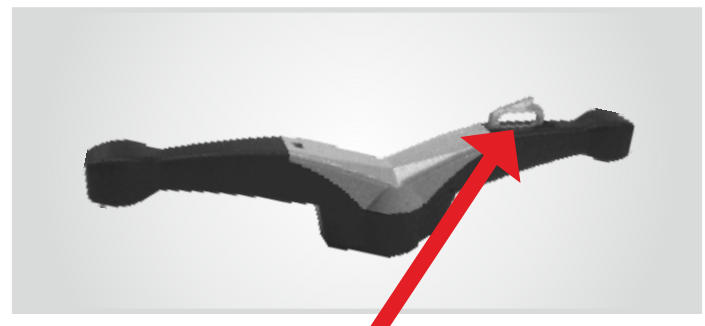

Double Sided Handle with padlock lever



Accessories

Auxiliary Contact Kit

It consists of two auxiliary contacts, each with 1 NO + 1 NC. This kit is pre-wired with terminal blocks and can be fitted at the site without increasing overall dimension.

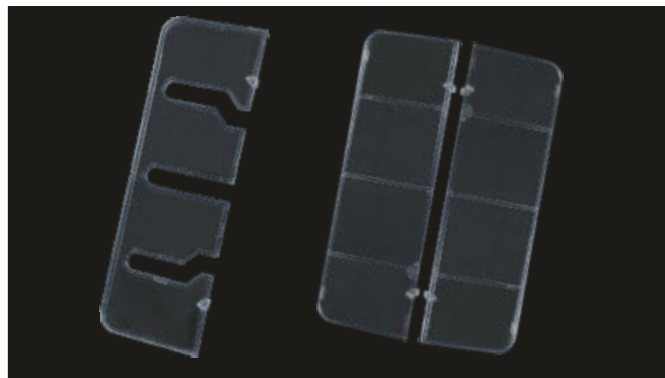

Inter-Phase Barriers

Made of transparent polycarbonate flame retardant material **Inter-phase barriers** are provided for additional safety to eliminate possibility of inter-phase short circuit.

Source Separator & Terminal Shroud

Made of transparent polycarbonate flame retardant material **Source Separator** is used to isolate two incoming supplies and to eliminate possibility of flash over between two supplies due to accidental falling of external objects.

Shrouds provide complete touch proof design and prevent accidental touching of live terminals. They are click fit type. Due to hinge type design terminal, shroud can be turned by 90 degree, hence terminals can be inspected without removing these shrouds.

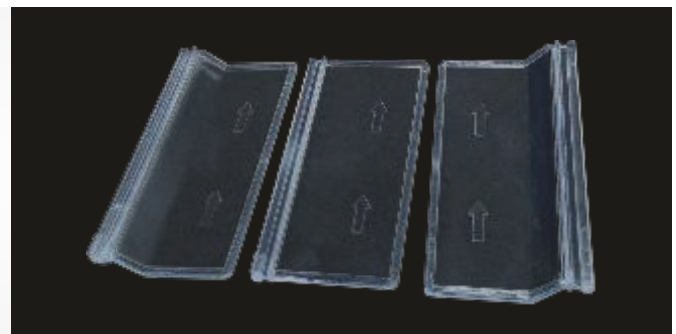

Bridging Bars

Bridging bars are provided between top and bottom terminal on common side.

Accessories to lock the changeover switch in OFF state and using this can have interlocking schemes with MCCB/ACB.



Castell Lock

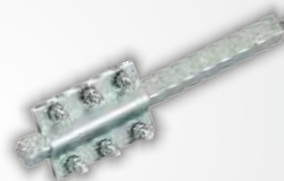

Extended Shaft



Door Inter Lock Assy.



On Load Changeover Switches



Specification

Electrical & Mechanical Characteristic

Specification

Current Rating

Frame Sizes	Frame-0			Frame-1			Frame-2	
Thermal Current (Ith) 40°C	63A	80A	100A	125A	160A	200A	250A	320A
Max. Normal rating of fuses	63	80	100	125	160	200	250	315
Insulation voltage Ui (Vac)	800	800	800	1000	1000	1000	1000	1000
Dielectric strength (Vac) 50 Hz 1 minute	4000	4000	4000	5000	5000	5000	5000	5000
Impulse voltage (KV)	6	6	6	6	6	6	8	8

Rated Operational Current Ie (A)

415 Vac: AC 23A	63	80	100	125	160	200	250	320
500 Vac: AC 23A	55	55	55	80	80	80	200	200
220V dc: DC 21A	63	80	100	125	160	200	250	250
220V dc: DC 22A	63	80	100	125	160	200	250	250
220V dc: DC 23A	63	63	63	125	125	125	200	200
440V dc: DC 21A	63	80	100	125	125	125	200	200
440V dc: DC22A	63	80	100	125	125	125	200	200
440V dc: DC 23A	63	63	63	125	125	125	200	200

Motor Power (KW) 415V

415 Vac without pre break Aux. Contact	30	30	30	63	70	80	132	160
500 Vac without pre break Aux. Contact	30	30	30	60	63	63	140	220
690 Vac without pre break Aux. Contact	22	22	22	50	55	55	90	150
415 Vac with pre break Aux. Contact	30	30	30	63	70	80	132	160
500 Vac with pre break Aux. Contact	30	30	30	70	80	80	160	220
690 Vac with pre break Aux. Contact	35	35	35	100	110	110	110	220
Motor Reactive 415 Vac (kVAR)	25	25	25	50	55	60	100	125

Overload Capacity

Short circuit current with fuses (kA RMS)	80	80	80	80	80	80	80	80
Fuse Rating	63	80	100	125	160	200	250	315
Peak short circuit making capacity (kA RMS)	15	15	15	20	20	20	30	45
Admissible short time current 1 sec (kA RMS)	5	5	5	7	7	7	13	13

Making & Breaking Characteristics

Breaking capacity (A RMS) 415 Vac pf=0.35	504	640	800	1000	1280	1600	2000	2520
Making capacity (A RMS) 415 Vac pf=0.35	630	800	1000	1250	1600	2000	2500	3150

Endurance

Mechanical Life (No. of Operations)	10000	10000	10000	8000	8000	8000	8000	5000
Electrical Life (No. of Operations)	2500	1500	1500	1000	1000	1000	1000	1000
Operating Torque (N-m)	3.5	3.5	3.5	9.5	9.5	9.5	11	11

Connection

Min. Cu. Cable / Bus bar size (mm ²)	16	25	35	50	70	95	120	185
Min. Al. Cable / Bus bar size (mm ²)	25	25X2	25X2	70	95	150	185	240



On Load Changeover Switches



Specification

Electrical & Mechanical Characteristic

Specification

Current Rating

Frame Sizes	Frame-3		Frame-4	Frame-5					
Thermal Current (I _{th}) 40°C	400A	630A	800A	1000A	1250A	1600A	2000A	2500A	3150A
Max. Normal rating of fuses	400	630	800	1000	1250	2 x 800	2 x 1000	2 x 1250	2 x 1250
Insulation voltage U _i (Vac)	1000	1000	1000	1000	1000	1000	1000	1000	1000
Dielectric strength (Vac) 50 Hz 1 minute	8000	8000	8000	8000	10000	10000	10000	10000	10000
Impulse voltage (KV)	12	12	12	12	12	12	12	12	12

Rated Operational Current I_e (A)

415 Vac: AC 23A	400	630	800	1000	1000	1000	1250	1250	1250
500 Vac: AC 23A	200	200	400	630	800	800	1000	1000	1000
260V dc: DC 21A	250	250	800	1000	1250	1250	1250	1250	1250
DC 22A	250	250	800	1000	1250	1250	1250	1250	1250
DC 23A	200	200	800	1000	1250	1250	1250	1250	1250
440V dc: DC 21A	200	200	800	1000	1250	1250	1250	1250	1250
DC 22A	200	200	800	1000	1250	1250	1250	1250	1250
DC 23A	200	200	800	1000	1250	1250	1250	1250	1250

Motor Power (KW) 415V

415 Vac without pre break Aux. Contact	200	220	450	560	560	560	710	710	710
500 Vac without pre break Aux. Contact	220	220	450	560	560	710	710	710	710
690 Vac without pre break Aux. Contact	150	150	185	400	400	475	475	750	750
415 Vac with pre break Aux. Contact	220	355	450	560	710	710	900	1100	1155
500 Vac with pre break Aux. Contact	280	355	550	710	710	900	900	1100	1100
690 Vac with pre break Aux. Contact	220	295	475	600	600	750	750	900	900
Motor Reactive 415 Vac (kVAR)	150	2 x 125	2 x 150	3 x 150	4 x 125	5x 150	6 x 150	7 x 150	9 x 150

Overload Capacity

Short circuit current with fuses (kA RMS)	80	80	80	80	80	80	80	80	80
Fuse Rating	400	630	800	1000	1250	2 x 800	2 x 1000	2 x 1250	2 x 1250
Peak short circuit making capacity (kA RMS)	45	45	55	105	105	110	110	110	120
Admissible short time current 1 sec (kA RMS)	13	13	26	50	50	50	50	50	55

Making & Breaking Characteristics

Breaking capacity (A RMS) 415 Vac pf=0.35	3200	5040	6400	8000	8000	8000	10000	10000	10000
Making capacity (A RMS) 415 Vac pf=0.35	4000	6300	8000	10000	10000	10000	12500	12500	12500

Endurance

Mechanical Life (No. of Operations)	5000	5000	4000	4000	4000	3000	3000	2500	2500
Electrical Life (No. of Operations)	1000	1000	500	500	500	500	500	500	500
Operating Torque (N-m)	17	17	40	40	40	40	60	60	60

Connection

Min. Cu. Cable / Bus bar size (mm ²)	30x5x2	40x5x2	50x5x2	60x5x2	80x5x2	100x5x2	100x5x3	100x5x4	100x10x3
Min. Al. Cable / Bus bar size (mm ²)	32x8x2	40x8x2	50x8x2	50x10x2	63x12x2	100x8x2	100x10x3	100x10x4	---

Dimensional Details 4P :

Changeover 63A To 100A

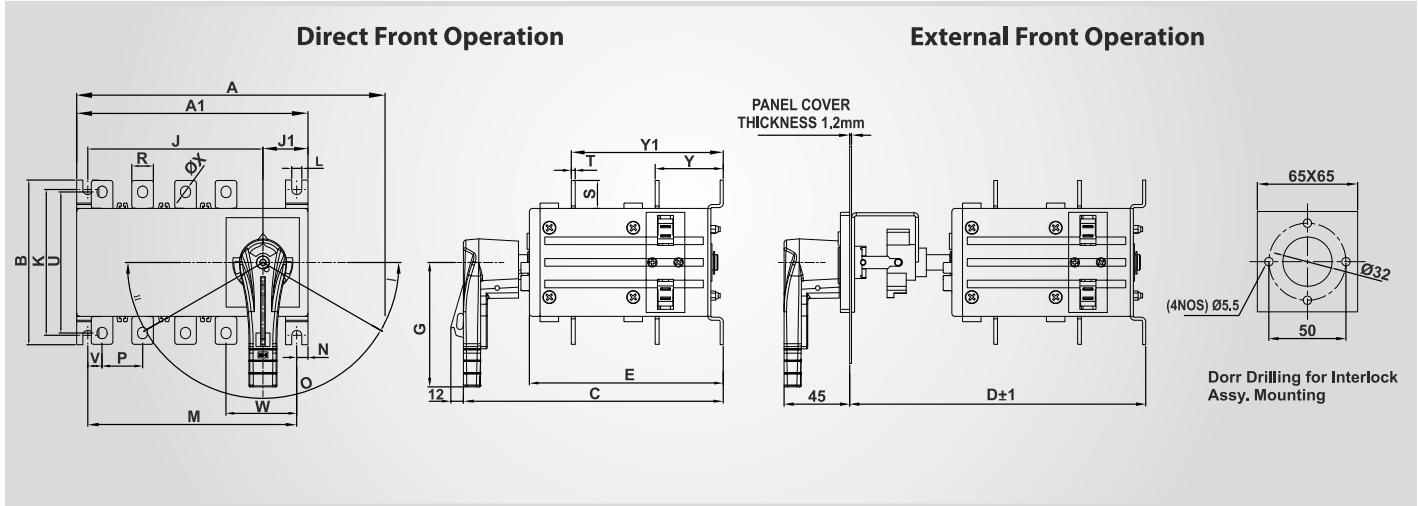

Over All Dimension		Fixing of SW.					Connection Terminal										SW. W.T.								
Rating	A	A1	B	C	D	E	G	J	J1	K	L	M	N	P	R	S	T	U	V	W	ØX	Y	Y1	Open Ex.	
Frame-0	4x63A	190	150	106	183	192	126	80	114	30	95	6.5	135	7.25	27	14	18	2.5	91	9.25	46	6.5	44	99	2 Kg.
	4x80A	190	150	106	183	192	126	80	114	30	95	6.5	135	7.25	27	14	18	2.5	91	9.25	46	6.5	44	99	2 Kg.
	4x100A	190	150	106	183	192	126	80	114	30	95	6.5	135	7.25	27	15	18	2.5	91	9.25	46	6.5	44	99	2 Kg.

Changeover 125A To 630A

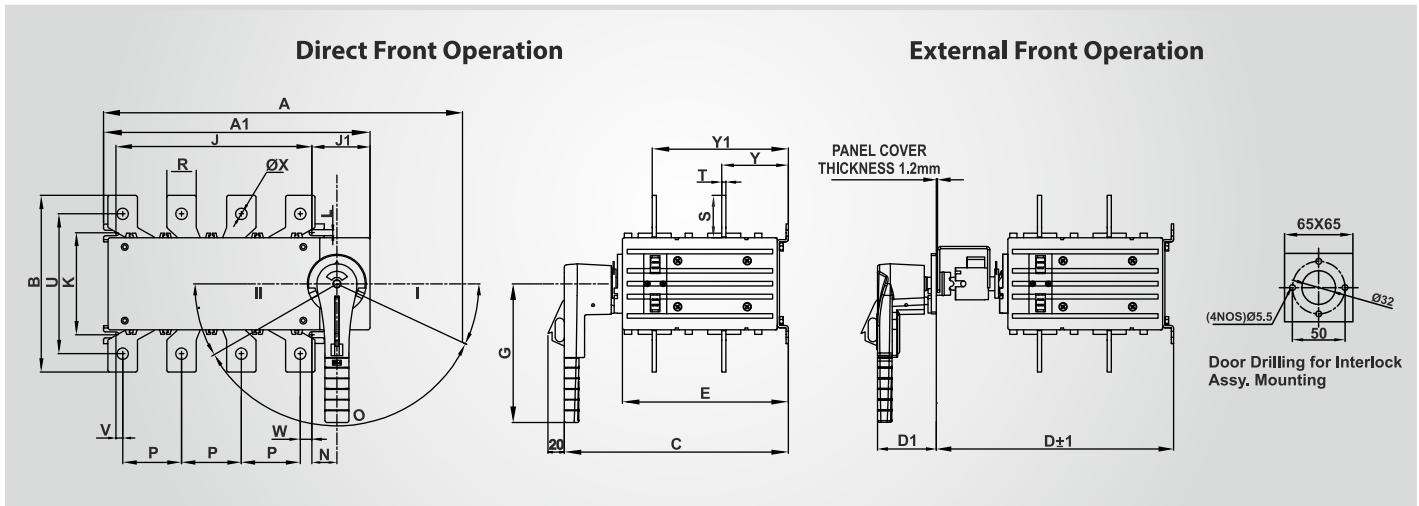

Over All Dimension		Fixing of SW.					Connection Terminal										SW. W.T.								
Rating	A	A1	B	C	D	D1	E	G	J	J1	K	L	N	P	R	S	T	U	V	W	ØX	Y	Y1	Open Ex.	
Frame-1	4x125A	305	228	141	227	240	65	160	116	162	57	95	6.5	26	44	22	28	3	118	15	15	8.5	64	130	4.0 Kg
	4x160A	305	228	155	227	240	65	160	116	162	57	95	6.5	26	47	25	35	4	123	10.5	10.5	10	64	130	5.0 Kg
	4x200A	305	228	155	227	240	65	160	116	162	57	95	6.5	26	47	25	35	4	123	10.5	10.5	10	64	130	5.0 Kg
Frame-2	4x250A	390	290	192	244	258	65	180	150	217	61	111	6.5	27	64	32	46	4.5	152	9.5	15	12.5	72	148	7.3 Kg
	4x320A	390	290	192	244	258	65	180	150	217	61	111	6.5	27	64	32	46	4.5	152	9.5	15	12.5	72	148	7.3 Kg
Frame-3	4x400A	472	372	240	314	320	65	250	150	280	80	180	9	40	72	40	40	5	206	30	30	11	95	203	14.0 Kg
	4x630A	472	372	270	314	320	65	250	150	280	80	180	9	40	80	55	55	5	230	20	20	14.5	95	203	17 Kg

Dimensional Details 4P : Changeover 800A To 1600A

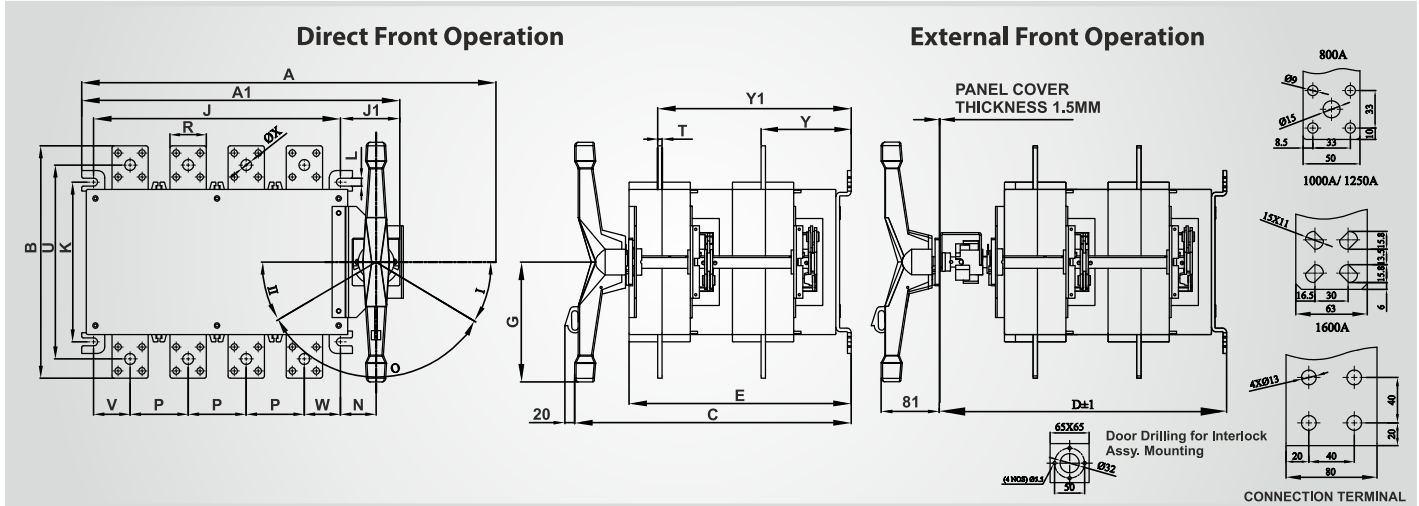

	Over All Dimension								Fixing of SW.					Connection Terminal								SW. W.T.			
	Rating	A	A1	B	C	D	D1	E	G	J	J1	K	L	N	P	R	S	T	U	V	W	ØX	Y	Y1	Open Ex.
Frame-4	4x800A	572	440	320	382	378	81	310	165	340	85	220	11	49	80	50	60	6	267	50	50	15	124	266	27.2 Kg
Frame-5	4x1000A	700	575	330	382	378	81	310	165	474	85	220	11	49	120	63	65	6	273	63	50	--	124	266	35.3 Kg
	4x1250A	700	575	330	382	378	81	310	165	474	85	220	11	49	120	63	65	7	273	63	50	--	125	267	37.0 Kg
	4x1600A	700	575	362	382	378	81	310	165	474	85	220	11	49	120	80	80	15	281	63	50	--	129	271	61.0 Kg

Changeover 2000A To 3150A

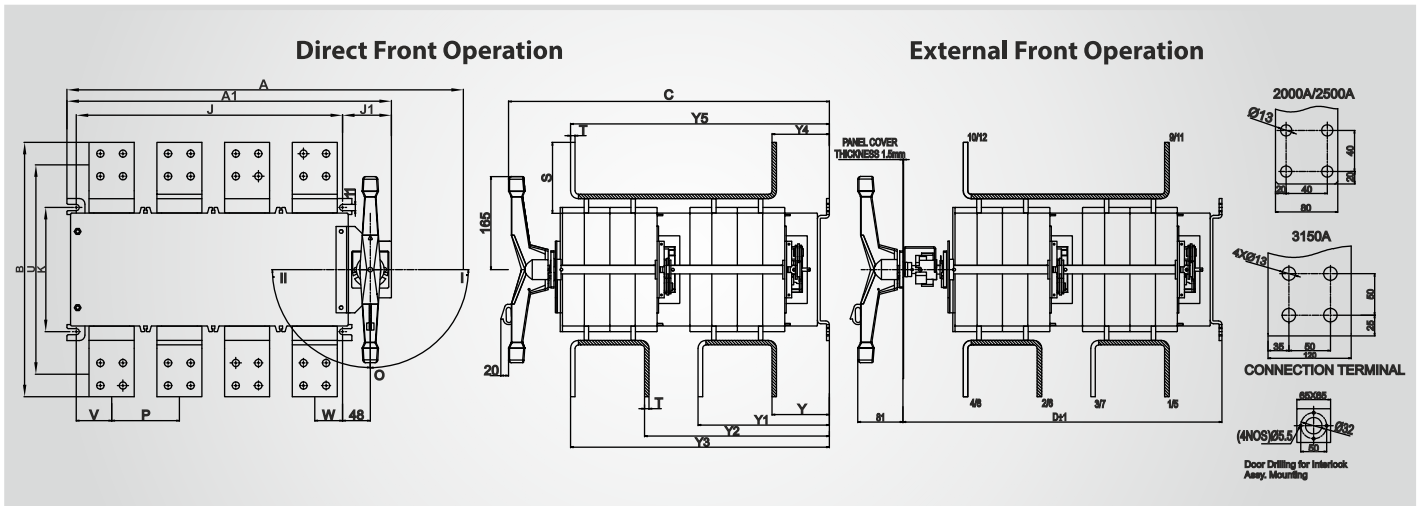

	Over All Dimension						Fixing of SW.				Connection Terminal								SW. W.T.	
	Rating	A	A1	B	C	D	J	J1	K	P	S	T	U	V	W	Y/Y4	Y1	Y2	Y3/Y5	Open Ex.
Frame-5	4x2000A	703	575	450	570	566	474	85	220	120	125	8	371	64	50	102	233	328	459	72 Kg.
	4x2500A	703	575	450	570	566	474	85	220	120	125	10	371	64	50	100	237	326	463	77.4 Kg.
	4x3150A	703	575	500	570	566	474	85	220	120	150	15	401	64	50	94	248	320	474	110 Kg.



On Load Changeover Switches



Dimensional Details 3P :

Changeover 63A To 100A

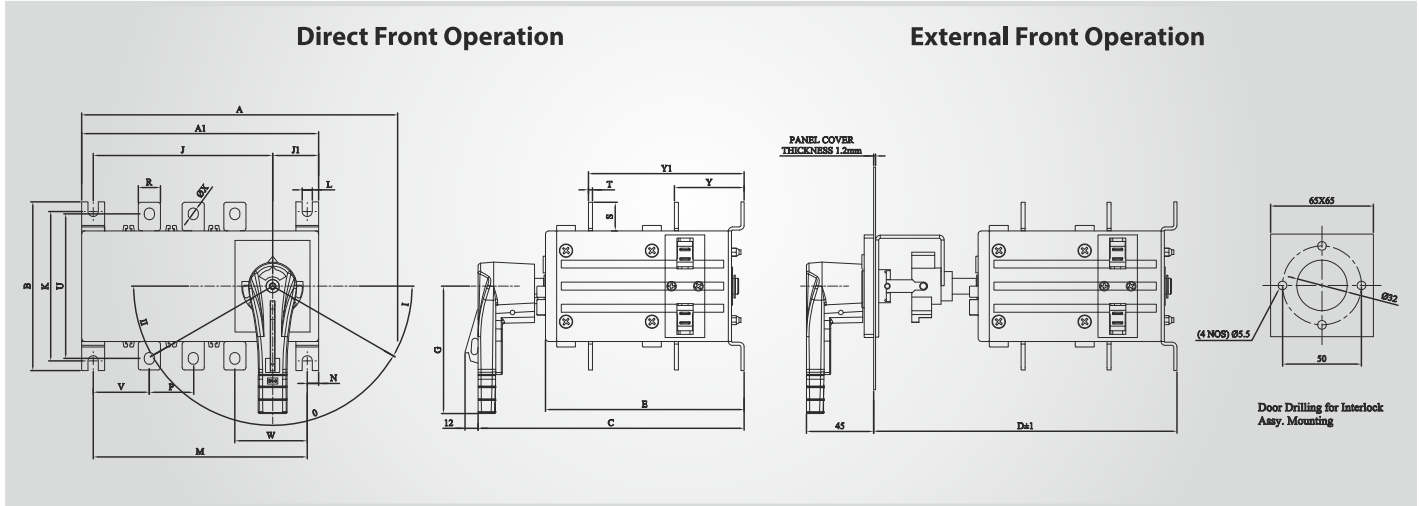

Over All Dimension		Fixing of SW.					Connection Terminal										SW. W.T.								
Rating	A	A1	B	C	D	E	G	J	J1	K	L	M	N	P	R	S	T	U	V	W	ØX	Y	Y1	Open Ex.	
Frame-0	3x63A	190	150	106	183	192	126	80	114	30	95	6.5	135	7.25	27	14	18	2.5	91	36	46	6.5	44	99	1.90 Kg.
	3x80A	190	150	106	183	192	126	80	114	30	95	6.5	135	7.25	27	14	18	2.5	91	36	46	6.5	44	99	1.90 Kg.
	3x100A	190	150	106	183	192	126	80	114	30	95	6.5	135	7.25	27	15	18	2.5	91	36	46	6.5	44	99	1.90 Kg.

Changeover 125A To 630A

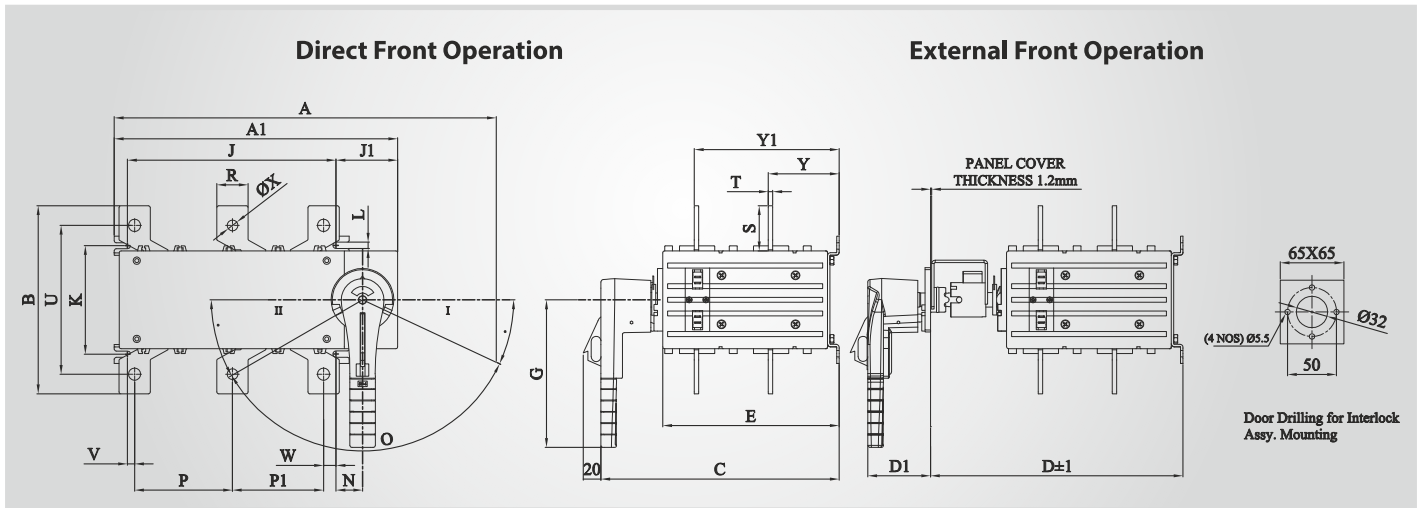

Over All Dimension		Fixing of SW.					Connection Terminal										SW. W.T.									
Rating	A	A1	B	C	D	D1	E	G	J	J1	K	L	N	P	P1	R	S	T	U	V	W	ØX	Y	Y1	Open Ex.	
Frame-1	3x125A	305	228	141	227	240	65	160	116	162	57	95	6.5	26	69	72	22	28	3	118	15	15	8.5	64	130	3.8 Kg
	3x160A	305	228	155	227	240	65	160	116	162	57	95	6.5	26	69	72	25	35	4	123	10.5	10.5	10	64	130	4.7 Kg
	3x200A	305	228	155	227	240	65	160	116	162	57	95	6.5	26	69	72	25	35	4	123	10.5	10.5	10	64	130	4.7 Kg
Frame-2	3x250A	390	290	192	244	258	65	180	150	217	61	111	6.5	27	93	100	32	46	4.5	152	9.5	15	12.5	72	148	6.8 Kg
	3x320A	390	290	192	244	258	65	180	150	217	61	111	6.5	27	93	100	32	46	4.5	152	9.5	15	12.5	72	148	6.8 Kg
Frame-3	3x400A	472	372	240	314	320	65	250	150	280	80	180	9	40	72	72	40	40	5	206	30	30	11	95	203	13 Kg
	3x630A	472	372	270	314	320	65	250	150	280	80	180	9	40	110	130	55	55	5	230	20	20	14.5	95	203	16 Kg



On Load Changeover Switches



Dimensional Details 3P :

Changeover 800A To 1600A

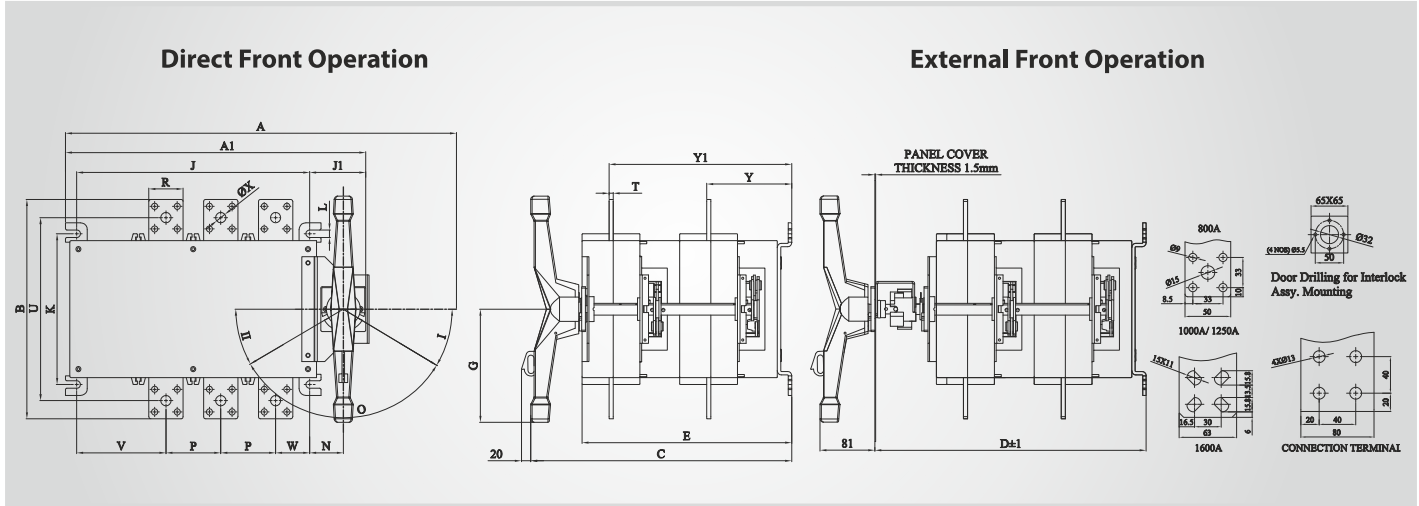

	Over All Dimension								Fixing of SW.					Connection Terminal								SW. W.T.			
	Rating	A	A1	B	C	D	D1	E	G	J	J1	K	L	N	P	R	S	T	U	V	W	ØX	Y	Y1	Open Ex.
Frame-4	3x800A	572	440	320	382	378	81	310	165	340	85	220	11	49	80	50	60	6	267	130	50	15	124	266	25 Kg
Frame-5	3x1000A	700	575	330	382	378	81	310	165	474	85	220	11	49	120	63	65	6	273	182	50	--	124	266	33Kg
	3x1250A	700	575	330	382	378	81	310	165	474	85	220	11	49	120	63	65	7	273	182	50	--	125	267	34.5Kg
	3x1600A	700	575	362	382	378	81	310	165	474	85	220	11	49	120	80	80	15	281	182	50	--	129	271	58.5Kg

Changeover 2000A To 3150A

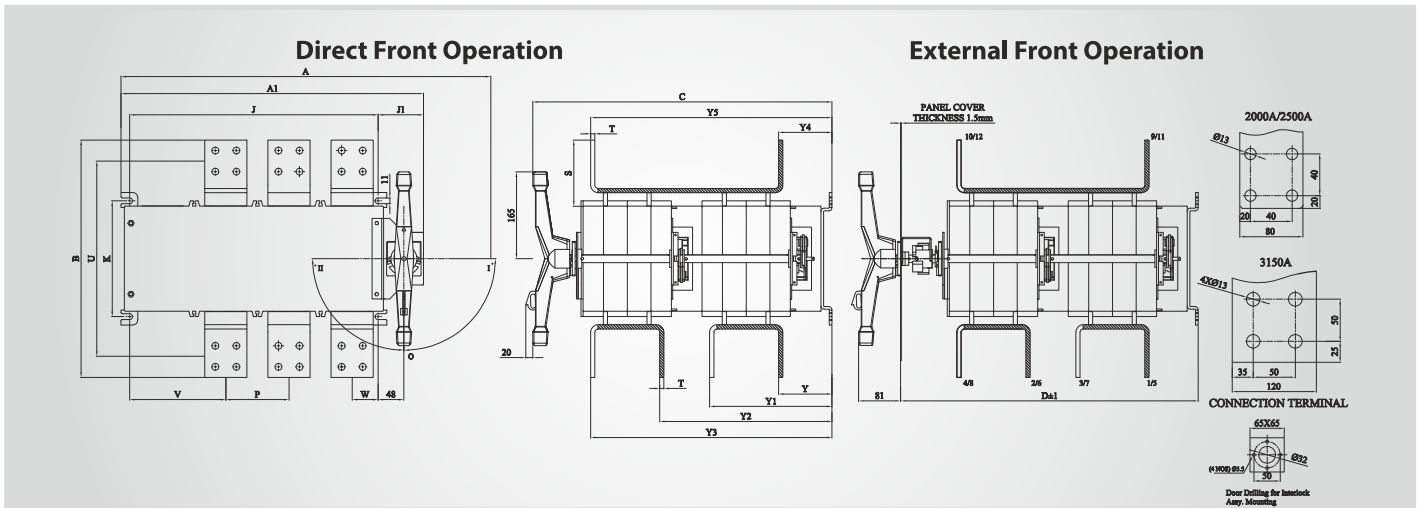

	Over All Dimension						Fixing of SW.					Connection Terminal								SW. W.T.
	Rating	A	A1	B	C	D	J	J1	K	P	S	T	U	V	W	Y/Y4	Y1	Y2	Y3/Y5	Open Ex.
Frame-5	3x2000A	703	575	450	570	566	474	85	220	120	125	8	371	182	50	102	233	328	459	65 Kg.
	3x2500A	703	575	450	570	566	474	85	220	120	125	10	371	182	50	100	237	326	463	71.5 Kg.
	3x3150A	703	575	500	570	566	474	85	220	120	150	15	401	182	50	94	248	320	474	100 Kg.



On Load Changeover Switches



OnLoad C/O Enclosed



Function

- On Load manual changeover between 2 sources.
- Emergency Breaking
- Selection between two loads
- Safe isolation of downstream loads for maintenance purpose

General Characteristics

- Black Handle Padlockable in I- O -II position
- CRCA Sheet (Door 1.2 mm & Body 1.6mm)... 63A to 800A
- CRCA Sheet (Door 1.6mm & Body 2.0mm)... 1000A to 3150A
- RAL 7035
- 2 External earthing points on each side
- Wall mounted with 4 bolts
- Door locking system allows opening of door only in OFF position
- Incoming & outgoing easily interchangeable at site
- Coating of epoxy polyester powder 70 micron
- Removable plate top & bottom
- Door with solid hinges



On Load Changeover Switches



References and Dimensions

Rating	Code	L	W	H	X	Y
63A	CDC00634PEAV	215	255	190	215	245
80A	CDC00804PEAV					
100A	CDC01004PEAV					
125A	C01254PEAV	290	365	240	325	320
160A	C01604PEAV					
200A	C02004PEAV					
250A	CO2504PEAV	350	455	258	415	380
320A	C03204PEAV					
400A	C04004PEAV					
630A	C06304PEAV	475	575	325	515	525
800A	C08004PEAV					
1000A	C10004PEAV					
1250A	C12504PEAV	800	655	410	600	825
1600A	C16004PEAV					
2000A	C20004PEAV					
2500A	C25004PEAV	800	750	596	685	825
3150A	C31504PEAV					

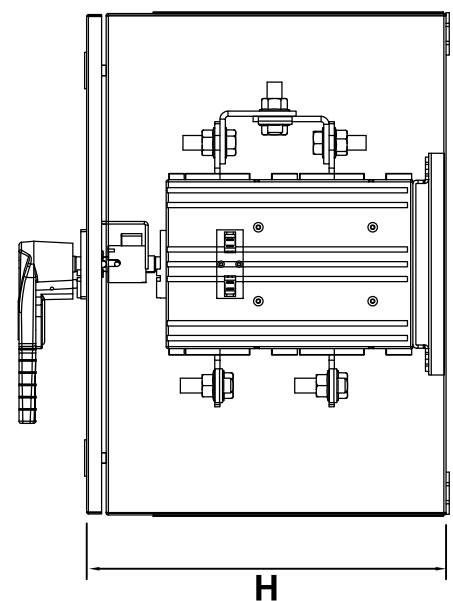
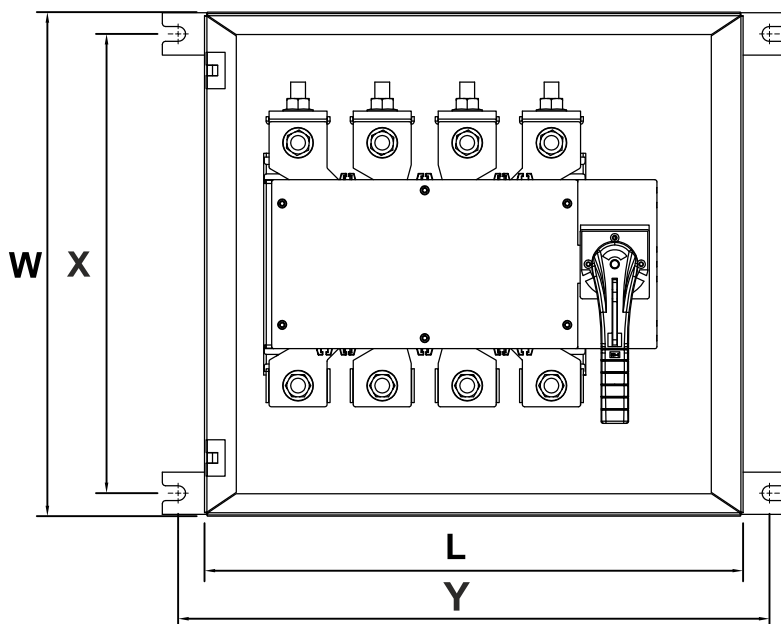

Note: All dimensions in mm



Other Product Range

Load Break Switch

- Range: 63A - 3150A, 4 Pole, 415V AC
- Conforms to IS / IEC 60947-3
- Tested at CPRI Bhopal for AC-23A duty
- Total Safety- all moving and live parts covered
- Compact design
- Quick make & quick break mechanism
- Unique safety handle with door pad locking
- Available in open execution and sheets steel enclosure



Switch Fuse Changeover

- Range: 125 - 630A, 4 Pole, 415V AC
- Conforms to IS / IEC 60947-3
- Tested at CPRI Bhopal for AC 23A utilisation category
- Total Safety- all moving and live parts covered
- Silver plated current carrying parts
- Flexibility for termination of supply
- Mounting possible in both horizontal & vertical position
- Available in Open Execution / Sheet Steel Enclosure

By Pass Switch

- Range: 125A - 1600A, 4 Pole, 415V AC
- Conforms to IS / IEC 60947-3
- Tested for AC-23A utilization category
- Total Safety- all moving and live parts covered
- Switch is designed for specific need in IT industries where UPS and servo stabilizer provides main source of supply
- Operated manually with double handle comfortably





Other Product Range

ATS

- Range 125A-630A, 4P, AC 23A, 3 frame sizes
- Trip Safety as standard feature, CE marked, RoHS Compliant
- Power monitoring- kWh, kVAh, kVAr, kVArh
- User selectable Rs232 & RS485 communications
- Configurable over riding voltage parameters
- Programable source priority

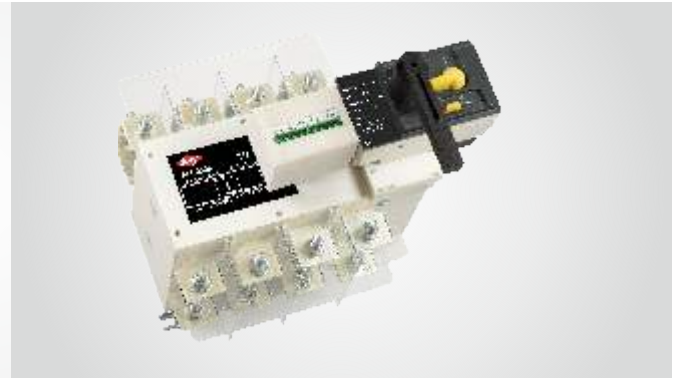

ACB

- Range : 630A – 6300A
- Operational voltage 690V & above
- Icu 50kA to 120kA at 500Vac
- Ics = 100% Icu throughout the range
- Icw : 50kA to 100kA (for 1 sec)
- Customer oriented Trip Relay - with advanced measurement functions & communication functions

Microprocessor MCCB

- Microprocessor range from 250A - 800A, Icu 36kA to 65kA.
- Adjustable overload, short circuit and ground fault with variable time setting and suitable for discrimination.
- Icu 36kA to 65kA, 3P & 4P (4PNutral fully protected). fixed and adjustable trip settings.



Controlgear

- Widest Range of 3P & 4P Contactors upto 800A.
- Capacitor Duty Contactors upto 62 kvar.
- Highest Electrical Life upto 2.5 million operations.
- Site mounted add on accessories (Auxiliary Contacts, Mechanical Interlock, Surge Suppressor, Timer, Mechanical Latch Units).
- Conformity to latest IEC/IS Standards.
- Type II Co-ordination. CE marked & UL Certified.

Branch Offices:

AHMEDABAD

B-802, Iscon Elegance, Nr. Prahlad Nagar Corner, Opp. Karnavati Club, S.G. Highway, Ahmedabad-380051
Ph.: 079 - 66168835/36
E-mail: ahmedabad@hplindia.com

BANGALORE

No.2D, IInd Floor, Farah Winsford, 133, Infantry Road, Bangalore - 560001
Ph.: 080-22863068/69
E-mail: bangalore@hplindia.com

BHUBANESWAR

N3-135, IRC Village, Nayabali, Behind Old Sai Baba Temple, Bhubaneswar-751012, Ph.: 0674-2550826
E-mail: orissa@hplindia.com

CHANDIGARH

SCO-14, 1st Floor, Industrial & Business Park, Phase-II, Chandigarh-160002
Ph.: 0172-2639157/ 8146404442
E-mail: chandigarh@hplindia.com

CHENNAI

"Amar Sindur" S-4, 2nd Floor, No.-43, Pantheon Road, Egmore, Chennai-600 008
Ph.: 044-28551530, 28551537
Fax: 044-42638243
E-mail: chennai@hplindia.com

COCHIN

1st Floor, A.K.S. Mahal Building, XL/7813J, Achutha Warriar Lane, M.G.Road, Ernakulam, Cochin-682035
Telefax: 0484-2354595
E-mail: cochin@hplindia.com

COIMBATORE

Designer Complex, Door No.130, C/2, 2nd Floor, Dr. Nanjappa Road, Coimbatore - 641018
Ph.: 0422-4393995
E-mail: coimbatore@hplindia.com

DEHRADUN

09/4/6, 1st Floor, East Canal Road, (Near Doon Defence Academy) Dehradun-248001
Ph.: 0135-2710567, 2710587
E-mail: Uttranchal@hplindia.com

GUWAHATI

Rajgarh Road, Opposite China Town Restaurant, Guwahati-781003
Ph.: 0361-2450889
E-mail: guwahati@hplindia.com

HUBLI

9-10, 1st Floor, Vernekar Plaza, Desh Pande Nagar, Hubli-580029
Ph.: 0836-4251463
E-mail: hubli@hplindia.com

HYDERABAD

No. 7-1-58, Flat No.403, 4th Floor, Concourse Building, Green Lands Road, Hyderabad-500016
Ph.: 040-66687878
E-mail: hyderabad@hplindia.com

INDORE

203, Millinda Manor 2, RNT Marg, Near Ravindra Natya Grah, Indore-452001, Ph.: 0731-4280525, 4225540
E-mail: Indore@hplindia.com

JAIPUR

512, 5th Floor, Plot No. 8-9, Corporate Park, Gopal Bari, Ajmer Road, Jaipur-302001
Ph.: 0141-4021035
E-Mail: jaipur@hplindia.com

JAMMU

Plot No.86, Yard No.6, Transport Nagar, Jammu-180006
E-mail: jammu@hplindia.com

KOLKATA

69, Ganesh Chandra Avenue, India House, 7th Floor, Block-C, Kolkata-700013
Ph.: +91 9038094379
E-Mail: calcutta@hplindia.com

LUCKNOW

1st Floor, Jain Building, 14/A5, Park Road Hazratganj ,Lucknow-226001
Ph.: 0522-4021687
E-Mail: lucknow@hplindia.com

LUDHIANA

09/4/6, 1st Floor, East Canal Road, (Near Doon Defence Academy) Dehradun-248001
Ph.: 0161-4062877
E-Mail: ludhiana@hplindia.com

MUMBAI

2C/H, Rushabh Chambers, 2nd Floor, Off-Makwana Road, Near Rubi Hotel, Marol, Andheri East, Mumbai-400059
E-mail: mumbai@hplindia.com

NAGPUR

Jagtap House, Plot No. 07, 1st Floor, Ganesh Gruh Nirman Society, Near Ganesh Mandir, Ring Road, Pratap Nagar, Nagpur-440022, Ph.: 0712-2222988
E-mail: nagpur@hplindia.com

PATNA

Hem Plaza, 5th Floor - 510 Frazer Road, Patna-800001(Bihar)
Ph. : +91 9334697299
E-mail: patna@hplindia.com

PUNE

Sunrise Skyline 3rd Floor, Plot No. 28/2 Scheme No. 11 B Opp. MSEB Office Somwar Peth Pune-411001 Ph.: +91 9028032724
E-mail: pune@hplindia.com

RAIPUR

1st Floor, Near Holy Heart School Chattisgarh College Road, Civil Line, Raipur (C.G.)-492006 Ph.: 0771-4218002/04
E-mail: raipur@hplindia.com

RANCHI

203, 2nd Floor, Mahalaxmi Complex, Line Tank Road, Ranchi-834001
Telefax: 0651-2206144
E-mail: ranchi@hplindia.com

SILIGURI

1st Floor, Parasuna Bhawan, Ward No.13, Udhm Singh Sarani, Asram Para, Siliguri-734001

VADODARA

409/410, Silver Oak Complex, Near Sainik Park, Char Rasta, Productivity Road, Akota, Vadodara - 390020 Gujarat
Ph.: 0265-2341747, Fax:0265-2352107
E-mail: baroda@hplindia.com

VIJAYAWADA

D.No.-29-37-135, 2nd Floor, G. R. Plaza, Eluru Road, Beside Canara Bank, Vijayawada-520002
Ph.: 0866-6622291
E-mail: vijayawada@hplindia.com

VIZAG

B.K. Towers, 49-34-1/63, 3rd Floor Akka Yyapalem Main Road, NH-5 Junction, Vizag-530016 (A.P.)
Ph.: 0891-2794506
E-mail: vizag@hplindia.com

Resident Offices:

Agartala	Balasure	Davangere	Jharsuguda	Moradabad	Silchar	Vapi
Agra	Belgaum	Durg	Jodhpur	Mysore	Surat	Varanasi
Allahabad	Berhampur	Goa	Kanyakumari	Nagercoil	Sholapur	Vellore
Anantpuram	Bhilai	Gorakhpur	Kolhapur	Nasik	Srinagar	
Aurangabad	Bhopal	Gulbarga	Kota	Patiala	Sambalpur	
Amravati	Bilaspur	Jabalpur	Madurai	Pondicherry	Tirupati	
Akola	Bijapur	Jabli	Malda	Rajkot	Trichy	
Angul	Calicut	Jamshedpur	Mangalore	Rourkela	Trivandrum	
Bareilly	Cuttack	Jalandhar	Meerut	Salem	Udaipur	



HPL Electric & Power Ltd

Corp. Office: Windsor Business Park, B-1D, Sector-10, Noida, U.P. - 201301, INDIA.

Tel.: +91-120-4656300, Fax: +91-120-4656333

Registered Office: 1/20, Asaf Ali Road, New Delhi - 110 002, INDIA.

E-mail: hpl@hplindia.com; enquiry@hplindia.com

Customer Care No. :
18004190198

www.hplindia.com