

Branch Offices:

AHMEDABAD

B-802, Iscon Elegance, Nr. Prahlad Nagar Corner, Opp. Karnavati Club, S.G. Highway, Ahmedabad-380 051
Ph.: 079 - 66168835
E-mail: ahmedabad@hplindia.com

BANGALORE

No.2D, 11nd Floor, Farah Winsford, 133, Infantry Road, Bangalore - 560 001
Ph.: 080-22863068/69
E-mail: bangalore@hplindia.com

BHUBANESWAR

N3-135, IRC Village, Nayabali, Behind Old Sai Baba Temple, Bhubaneswar-751 012 Ph.: 0674-2550826
E-mail: orissa@hplindia.com

CHANDIGARH

Plot No. 57, 5th Floor Industrial & Business Park, Phase-1 Chandigarh - 160002 Ph.: 0172-2639157
E-mail: chandigarh@hplindia.com

CHENNAI

"Amar Sindur" S-4, 2nd Floor, No.-43, Pantheon Road, Egmore, Chennai-600 008
Ph.: 044-28551530, 28551537
Fax : 044-42638243
E-mail: chennai@hplindia.com

COCHIN

1st Floor, A.K.S. Mahal Building, XL/7813J, Achutha Warriar Lane, M.G.Road, Ernakulam, Cochin-682 035
Telefax : 0484-2354595
E-mail: cochin@hplindia.com

COIMBATORE

Designer Complex, Door No.130, C /2, 2nd Floor, Dr. Nanjappa Road, Coimbatore - 641018
Ph.:0422-4393995
E-mail: coimbatore@hplindia.com

DEHRADUN

09/4/6, 1st Floor, East Canal Road, (Near Doon Defence Academy) Dehradun-248001
Ph.: 0135-2710567, 2710587
E-mail: Ultranchal@hplindia.com

GUWAHATI

Rajgarh Road, Opposite China Town Restaurant Guwahati - 781 003
Ph.: 0361-2450889
E-mail: guwahati@hplindia.com

HUBLI

9-10, 1st Floor, Vernekar Plaza, Desh Pande Nagar, Hubli-580029
Ph.: 0836-4251463
E-mail: hubli@hplindia.com

HYDERABAD

No. 7-1-58, flat No.403, 4th Floor, Concourse Building, Green Lands Road, Hyderabad - 500 016
Ph.: 040-40035959
E-mail: hyderabad@hplindia.com

INDORE

203, Millinda Manor 2 RNT Marg, Near Ravindra Natya Grah, Indore- 452 001,
Ph.: 0731-4280525, 4225540
E-mail: Indore@hplindia.com

JAIPUR

512, 5th floor, Plot No. 8-9, Corporate Park, Gopal Bari, Ajmer Road Jaipur - 302 001
Ph. : 0141-4021035
E-Mail: jaipur@hplindia.com

JAMMU

Plot No.86 Yard No.6 Transport Nagar, Jammu- 180006
E-mail: jammu@hplindia.com

KANPUR

17/14, 2nd Floor, Opposite Nanarao Park, The Mall, Kanpur - 208 001 (U.P.)
Ph.: 0512-2316017
E-mail: kanpur@hplindia.com

KOLKATA

69, Ganesh Chandra Avenue, India House 7th Floor, Block-C, Kolkata - 700 013
Ph.: 033-65394379
E-Mail: calcutta@hplindia.com

LUCKNOW

1st Floor, Jain Building, 14/A5, Park Road Hazratganj, Lucknow
Ph.: 0522-4021687
E-Mail: lucknow@hplindia.com

LUDHIANA

698 - D, Model Town, Extn., Opp. silverstone Hotel, Ludhiana-141 003
Ph. : 0161-4062877
E-Mail : ludhiana@hplindia.com

MUMBAI

2C/H, Rushabh Chambers 2nd Floor, Off-Makwana Road, Near Rubi Hotel Marol Andheri East Mumbai - 400 059
Ph.: 022-61830810-20 Telefax: 022-28528181
E-mail: mumbai@hplindia.com

NAGPUR

Jagtap House, Plot No. 07, 1st Floor, Ganesh Gruh Nirman Society, Near Ganesh Mandir, Ring Road, Pratap Nagar, Nagpur - 440022,
Ph.: 0712-2222988
E-mail: nagpur@hplindia.com

PATNA

Hem Plaza, 5th Floor - 510 Frazer Road, Patna - 800001(Bihar)
Ph. : 09334697299
E-mail: patna@hplindia.com

PUNE

Sunrise Skyline 3rd Floor, Plot No. 28/2 Scheme No. 11 B Opp. MSEP Office Somwar Peth Pune - 411 001 Ph. : 020-69200902
E-mail: pune@hplindia.com

RAIPUR

1st Floor, Near Holy Heart School Chattisgarh College Road, Civil Line, Raipur (C.G.)-492 006 Ph.:0771-6541590
E-mail: raipur@hplindia.com

RANCHI

203, Mahalaxmi Complex, Line Tank Road, 2nd Floor Ranchi - 834 001
Telefax : 0651-2206144
E-mail : ranchi@hplindia.com

SILIGURI

1st Floor, Parasuna Bhawan, Ward No.13, Udham Singh Sarani, Asram Para, Siliguri-734001

VADODARA

409/410, Silver Oak Complex, Near Sainik Park Char Rasta, Productivity Road, Akota, Vadodara - 390020 Gujarat
Ph.: 0265-2341747 Fax:0265-2352107
E-mail : baroda@hplindia.com

VIJAYAWADA

D.No.-29-37-135, 2nd Floor, G. R. Plaza, Eluru Road, Beside Canara Bank, Vijayawada-520 002
Ph.: 0866-6622291
E-mail : vijayawada@hplindia.com

VIZAG

B.K. Towers, 49-34-1/63, 3rd Floor Akka Yyapalem Main Road, NH-5 Junction, Vizag-530 016 (A.P.)
Ph.: 0891-2794506
E-mail : vizag@hplindia.com

Resident Offices:

Agartala	Balasore	Davangere	Jharsuguda	Moradabad	Silchar	Vapi
Agra	Belgaum	Durg	Jodhpur	Mysore	Surat	Varanasi
Allahabad	Berhampur	Goa	Kanyakumari	Nagerkoil	Sholapur	Vellore
Anantpuram	Bhilai	Gorakhpur	Kolhapur	Nasik	Srinagar	
Aurangabad	Bhopal	Gulbarga	Kota	Patiala	Sambalpur	
Amravati	Bilaspur	Jabalpur	Madurai	Pondicherry	Tirupati	
Akola	Bijapur	Jabli	Malda	Rajkot	Trichy	
Angul	Calicut	Jamshedpur	Mangalore	Rourkela	Trivandrum	
Bareilly	Cuttack	Jalandhar	Meerut	Salem	Udaipur	



HPL Electric & Power Ltd

Corp. Office : Windsor Business Park, B-1D, Sector-10, Noida, U.P. - 201301, INDIA.
Tel.: +91-120-4656300, Fax: +91-120-4656333
Registered Office : 1/21, Asaf Ali Road, New Delhi - 110 002, INDIA.
E-mail : hpl@hplindia.com; enquiry@hplindia.com

Customer Care No. :
18004190198

www.hplindia.com



Cubicle Load Break Switch from 63A to 3150A



HP/CLBS/01-18

www.hplindia.com



Cubicle Load Break Switch



Application

The HPL make Cubicle Load Break Switch is 4 Pole manually operated, consisting of two sets of terminals for connecting to incoming supply & load. It ensures safe isolation and is suitable for use in individual enclosures, switch boards, lighting and power panels etc. with following features :-

- Suitable for incoming and outgoing feeders
- 2 stable positions (I – O)
- Fully visualized breaking
- Pre equipped terminal cover, phase barrier with all ratings
- Compact design - saves panel space / supports easy maintenance
- Quick Make & Break type irrespective of human torque
- Resistant to Tropical conditions & polluted environment
- High thermal & dynamic withstand capacity
- Self extinguishing fiberglass re-inforced insulating body
- Available in Open execution, Steel sheet Enclosure & Direct Mounted type
- AC 23 A Category
- Bounce free contacts
- Any pole can be used as Neutral pole... true 4 pole switch
- Unique Safety Handle with built in door padlock facility
- 3 lock pad lock, lockable in ON & OFF positions
- Castle lock, interlocking two isolators
- High Electrical & Mechanical life

HIGHLIGHTS

- » Conforms to IS/IEC:60947-3
- » Available in 6 frame sizes... rated current from 63A to 3150A
- » Compact Design
- » Quick Make & Quick Break mechanism (spring load contact)
- » Clear indication of 'ON' & 'OFF' Position (I-O)
- » High Mechanical & Electrical life
- » Arc chute plates to enhance contact life
- » 100% Neutral rating... true 4 pole switch
- » Line load reversibility
- » Vertical or lateral mounting
- » Suitable for both aluminum & copper termination
- » Total safety : All moving and live parts covered
- » Terminal cover, phase barrier as standard feature
- » ROHS Compliant
- » Wide range of accessories



- Terminal Shroud & Phase barrier as standard design product
- Enclosed operating rod
- 3 lock pad lockable handle in both ON & OFF positions



Self Fire Extinguishing



Load Line Reversibility



Positive Isolation

Approvals & Test

- Time tested
- Customer Accepted
- CPRI Tested
- ISO 9001 Certified



Globally Accepted exporting to over 25 countries



Cubicle Load Break Switch



Overview (Operations)

Direct

The pad lockable handle is mounted directly on the Cubicle Load Break Switch and is lockable in OFF & ON position.

External

The pad lockable handle is to be mounted on the panel door and lockable in OFF position. The external front operation ensures that the door is locked in ON position.

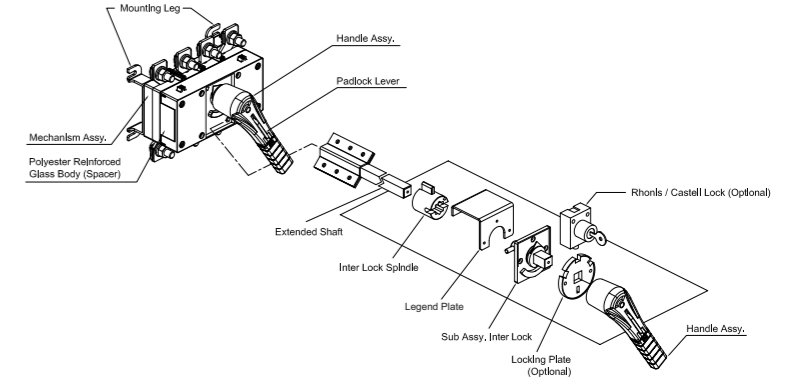

Accessories

Handle up to 630A



Handle for 800A and above

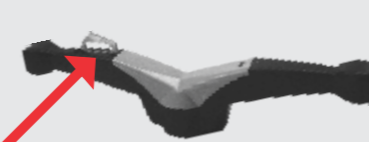

Handle with padlock lever

Auxiliary Contact

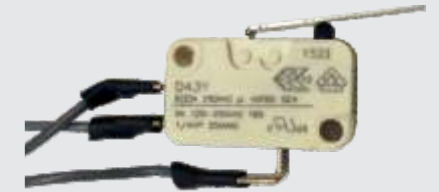

Castell Lock



Extended Shaft



Door Inter Lock Assy.

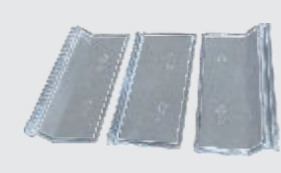

Inter-Phase barriers



Terminal Shroud

Arc Chute Plates

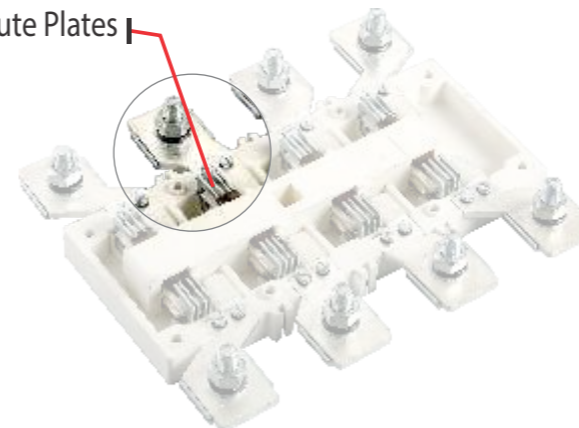

Working Principle:

Arc Chamber

The Arc Chamber is specially designed and provided with arc chute plates with an arc channel as a flow guide to reduce the arc length, thereby improving the capability of extinguishing the arc. This enhances the life of the moving & stationary contacts thereby increasing the life of the product.



Cubicle Load Break Switch



Specification Electrical & Mechanical Characteristic

Specification	Current Rating							
	Frame-0			Frame-1			Frame-2	
Frame Sizes	63A	80A	100A	125A	160A	200A	250A	320A
Thermal Current (Ith) 40°C	63	80	100	125	160	200	250	315
Max. Normal rating of fuses	63	80	100	125	160	200	250	315
Insulation voltage Ui (Vac)	750	750	750	1000	1000	1000	1000	1000
Dielectric strength (Vac) 50 Hz 1 minute	4000	4000	4000	5000	5000	5000	5000	5000
Impulse voltage (KV)	6	6	6	6	6	6	8	8

Rated Operational Current Ie (A)

415 Vac: AC 23A	63	80	100	125	160	200	250	320
415 Vac: AC 21A	63	80	100	125	160	200	250	320
500 Vac: AC 23A	55	55	55	100	130	160	200	250
260V dc: DC 21A	63	80	100	125	160	200	250	320
DC 22A	63	80	100	125	160	200	250	320
DC 23A	63	63	63	125	160	160	200	250
440V dc: DC 21A	63	80	100	125	160	200	250	320
DC 22A	63	80	100	125	130	160	200	250
DC 23A	63	63	63	125	130	160	200	250

Motor Power (KW) 415V

415 Vac without pre break Aux. Contact	30	30	30	63	70	80	132	160
500 Vac without pre break Aux. Contact	30	30	30	60	63	63	140	220
690 Vac without pre break Aux. Contact	22	22	22	50	55	55	90	150
415 Vac with pre break Aux. Contact	30	30	30	63	70	80	132	160
500 Vac with pre break Aux. Contact	30	30	30	70	80	80	160	220
690 Vac with pre break Aux. Contact	35	35	35	100	110	110	110	220
Motor Reactive 415 Vac (kVAR)	25	25	25	50	55	60	100	125

Overload Capacity

Short circuit current with fuses (kA RMS)	80	80	80	80	80	80	80	80
Fuse Rating	63	80	100	125	160	200	250	315
Peak short circuit making capacity (kA RMS)	15	15	15	20	20	20	30	45
Admissible short time current 1 sec (kA RMS)	5	5	5	7	7	7	13	13

Making & Breaking Characteristics

Breaking capacity (A RMS) 415 Vac pf=0.35	504	504	504	1000	1280	1600	2000	2520
Making capacity (A RMS) 415 Vac pf=0.35	630	630	630	1250	1600	2000	2500	3150

Endurance

Mechanical Life (No. of Operations)	10000	10000	10000	8000	8000	8000	8000	5000
Electrical Life (No. of Operations)	2500	1500	1500	1000	1000	1000	1000	1000
Operating Torque (N-m)	3.5	3.5	3.5	9.5	9.5	9.5	11	11

Connection

Min. Cu. Cable / Bus bar size (mm ²)	16	25	25	50	70	95	120	185
Min. Al. Cable / Bus bar size (mm ²)	25	25X2	25X2	70	95	150	185	240



Cubicle Load Break Switch



Specification Electrical & Mechanical Characteristic

Specification	Current Rating								
	Frame-3			Frame-4	Frame-5				
Frame Sizes	400A	630A	800A	1000A	1250A	1600A	2000A	2500A	3150A
Thermal Current (Ith) 40°C	400	630	800	1000	1250	1600	2000	2500	3150
Max. Normal rating of fuses	400	630	800	1000	1250	2 x 800	2 x 1000	2 x 1250	2 x 1250
Insulation voltage Ui (Vac)	1000	1000	1000	1000	1000	1000	1000	1000	1000
Dielectric strength (Vac) 50 Hz 1 minute	8000	8000	8000	8000	10000	10000	10000	10000	10000
Impulse voltage (KV)	12	12	12	12	12	12	12	12	12

Rated Operational Current Ie (A)

415 Vac: AC 23A	400	630	800	1000	1000	1000	1250	1250	1250
415 Vac: AC 21A	400	630	800	1000	1250	1600	2000	2500	3150
500 Vac: AC 23A	315	315	630	1000	1000	1000	1000	1000	1000
260V dc: DC 21A	400	630	800	1000	1250	1600	2000	2000	2000
DC 22A	400	500	800	1000	1250	1250	1250	1250	1250
DC 23A	400	500	800	1000	1250	1250	1250	1250	1250
440V dc: DC 21A	400	500	630	1000	1250	1600	2000	2000	2000
DC 22A	400	500	800	1000	1250	1250	1250	1250	1250
DC 23A	400	500	800	1000	1000	1000	1000	1000	1000

Motor Power (KW) 415V

415 Vac without pre break Aux. Contact	200	220	450	560	560	560	710	710	710
500 Vac without pre break Aux. Contact	220	220	450	560	560	710	710	710	710
690 Vac without pre break Aux. Contact	150	150	185	400	400	475	475	750	750
415 Vac with pre break Aux. Contact	220	355	450	560	710	710	900	1100	1155
500 Vac with pre break Aux. Contact	280	355	550	710	710	900	900	1100	1100
690 Vac with pre break Aux. Contact	220	295	475	600	600	750	750	900	900
Motor Reactive 415 Vac (kVAR)	150	2 x 125	2 x 150	3 x 150	4 x 125	5x 150	6 x 150	7 x 150	9 x 150

Overload Capacity

Short circuit current with fuses (kA RMS)	80	80	80	80	80	80	80	80	80
Fuse Rating	400	630	800	1000	1250	2 x 800	2 x 1000	2 x 1250	2 x 1250
Peak short circuit making capacity (kA RMS)	45	45	55	105	105	110	110	110	120
Admissible short time current 1 sec (kA RMS)	13	13	26	50	50	50	50	50	55

Making & Breaking Characteristics

Breaking capacity (A RMS) 415 Vac pf=0.35	3200	5040	6400	8000	8000	8000	10000	10000	10000
Making capacity (A RMS) 415 Vac pf=0.35	4000	6300	8000	10000	10000	10000	12500	12500	12500

Endurance

Mechanical Life (No. of Operations)	5000	5000	4000	4000	4000	3000	3000	2500	2500
Electrical Life (No. of Operations)	1000	1000	500	500	500	500	500	500	500
Operating Torque (N-m)	17	17	40	40	40	40	60	60	60

Connection

Min. Cu. Cable / Bus bar size (mm ²)	30x5x2	40x5x2	50x5x2	60x5x2	80x5x2	100x5x2	100x5x3	100x5x4	100x10x3
Min. Al. Cable / Bus bar size (mm ²)	32x8x2	40x8x2	50x8x2	50x10x2	63x12x2	100x8x2	100x10x3	100x10x4	-----



Cubicle Load Break Switch



Dimensional Details 4P:

Load Break Switch 63A To 100A

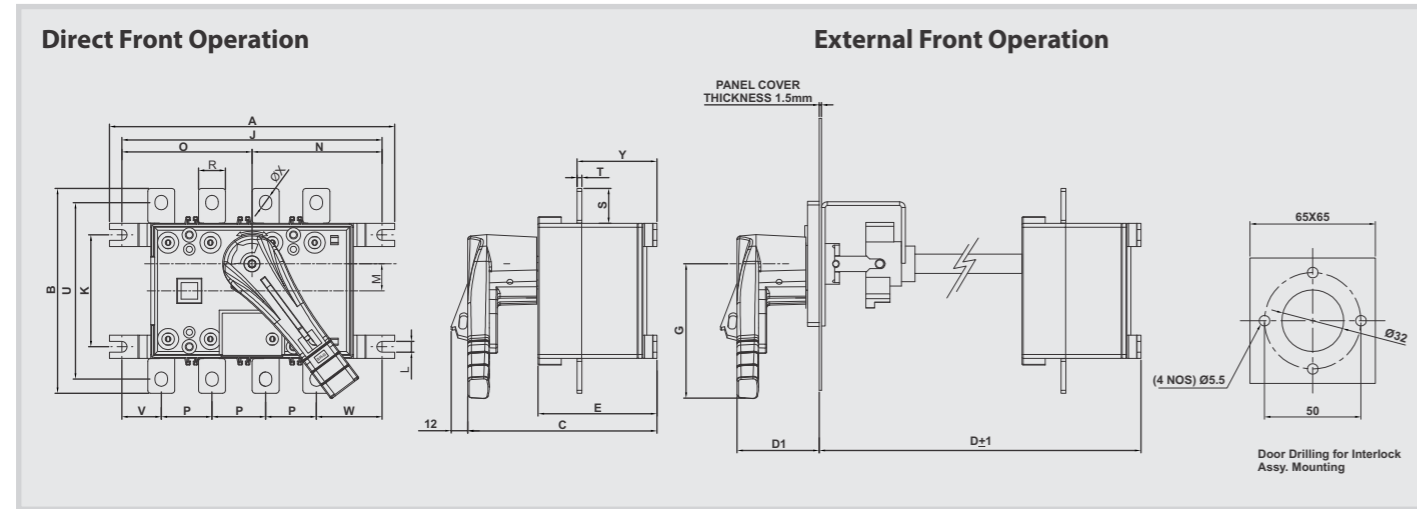

Over All Dimension		Fixing of SW.					Connection Terminal										SW. W.T.						
Rating	A	B	C	D	D1	E	G	J	K	L	M	N	O	P	R	S	T	U	V	W	ØX	Y	Open Ex.
4x63A	148	106	98	126	45	62	80	135	58	5.5	14	67.5	67.5	27	14	18	2.5	91	20.5	34	6.5	42	1 Kg.
4x80A	148	106	98	126	45	62	80	135	58	5.5	14	67.5	67.5	27	14	18	2.5	91	20.5	34	6.5	42	1 Kg.
4x100A	148	106	98	126	45	62	80	135	58	5.5	14	67.5	67.5	27	15	18	2.5	91	20.5	34	6.5	42	1 Kg.

Load Break Switch 125A To 630A

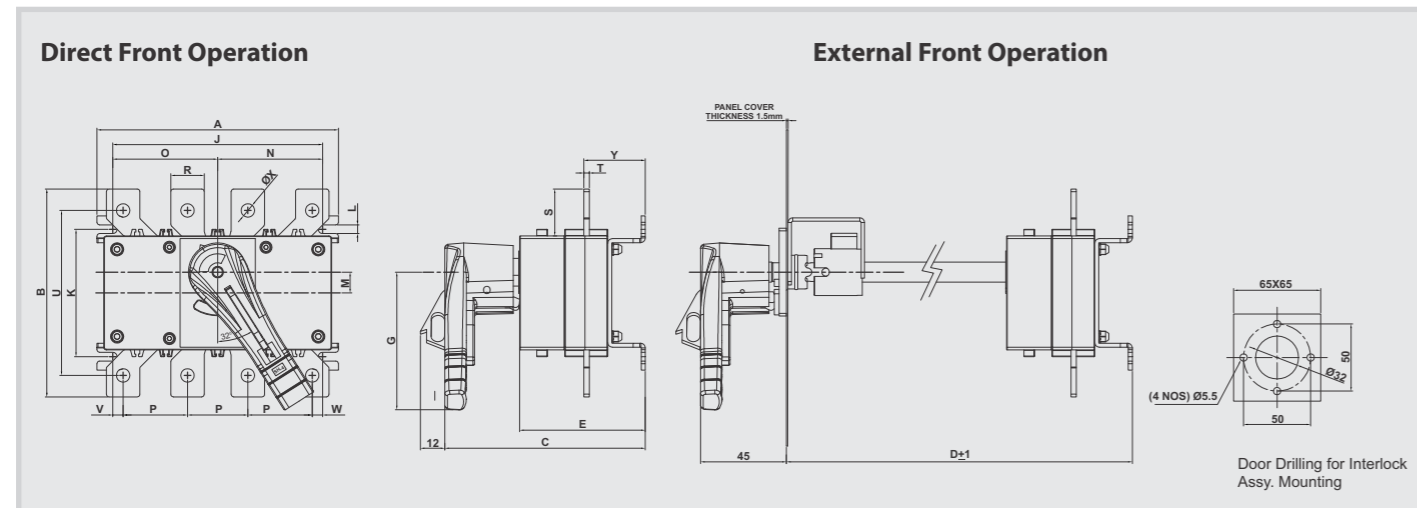

Over All Dimension		Fixing of SW.					Connection Terminal										SW. W.T.					
Rating	A	B	C	D	E	G	J	K	L	M	N	O	P	R	S	T	U	V	W	ØX	Y	Open Ex.
4x125A	180	141	150	164	94	116	162	95	6.5	15	81	81	44	22	28	3	118	15	15	8.5	46	1.8 Kg.
4x160A	180	155	150	164	94	116	162	95	6.5	15	81	81	47	25	35	4	123	10.5	10.5	10	46	2.1 Kg.
4x200A	180	155	150	164	94	116	162	95	6.5	15	81	81	47	25	35	4	123	10.5	10.5	10	46	2.1 Kg.
4x250A	240	192	160	176	104	150	217	111	6.5	20	109	109	64	32	46	4.5	152	15	9.5	12.5	48	3.1 Kg.
4x320A	240	192	160	176	104	150	217	111	6.5	20	109	109	64	32	46	4.5	152	15	9.5	12.5	48	3.1 Kg.
4x400A	304	240	200	192	144	150	280	180	9	30	140	140	72	40	40	5	206	30	30	11	69	6.0 Kg.
4x630A	304	270	200	192	144	150	280	180	9	30	140	140	80	55	55	5	230	20	20	14.5	69	7.0 Kg.



Cubicle Load Break Switch



Dimensional Details 4P:

Load Break Switch 800A To 1600A

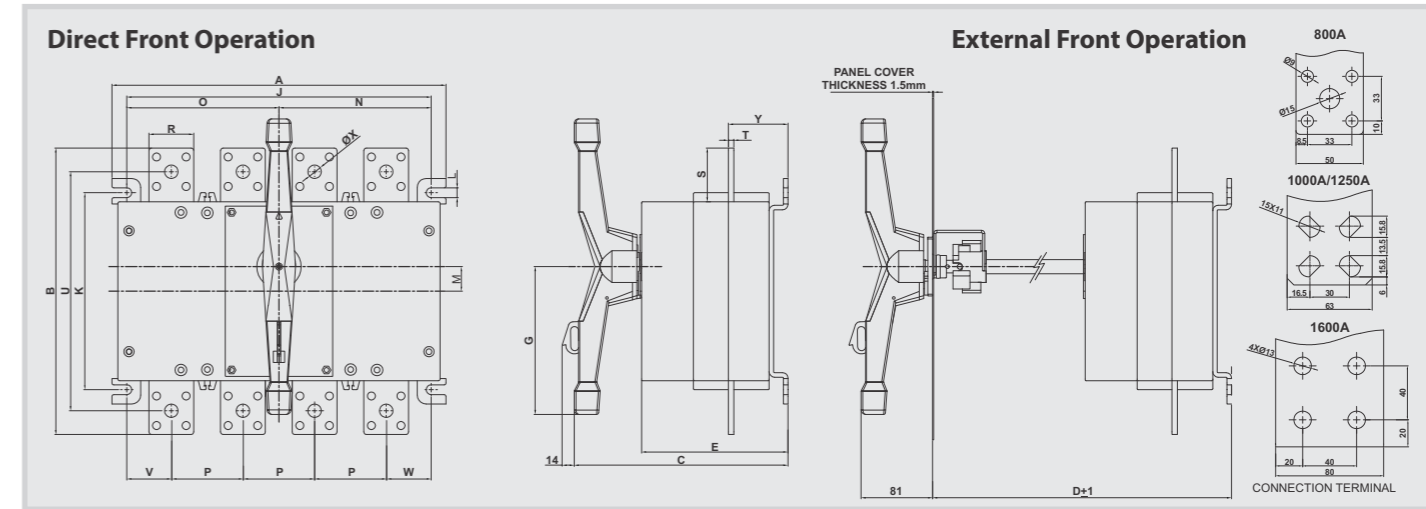

Over All Dimension		Fixing of SW.					Connection Terminal										SW. W.T.					
Rating	A	B	C	D	E	G	J	K	L	M	N	O	P	R	S	T	U	V	W	ØX	Y	Open Ex.
4x800A	373	320	235	234	164	165	340	220	11	28	170	170	80	50	60	6	267	50	50	15	67	11.7Kg.
4x1000A	505	330	235	234	164	165	474	220	11	28	237	237	120	63	65	6	273	50	63	--	65	16.5 Kg.
4x1250A	505	330	235	234	164	165	474	220	11	28	237	237	120	63	65	7	273	50	63	--	66	16.8 Kg.
4x1600A	505	361	235	234	164	165	474	220	11	28	237	237	120	80	80	15	281	50	63	--	70	23.0 Kg.

Load Break Switch 2000A To 3150A

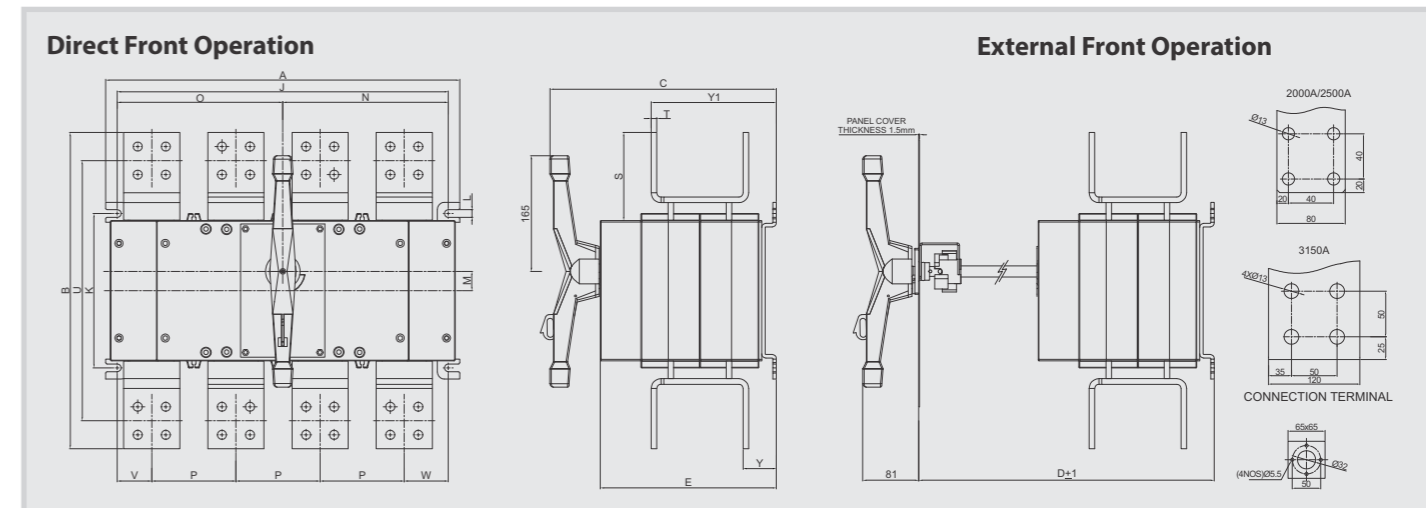

Over All Dimension		Fixing of SW.					Connection Terminal										SW. W.T.			
Rating	A	B	C	D	E	G	J	K	M	N	O	P	S	T	U	V	W	Y	Y1	Open Ex.
4x2000A	505	450	323	335	251	474	220	28	237	237	120	125	8	371	50	64	72	155		38.0 Kg.
4x2500A	505	450	323	335	251	474	220	28	237	237	120	125	10	371	50	64	73	156		39.5 Kg.
4x3150A	505	500	323	335	251	474	220	28	237	237	120	150	15	401	50	64	75	159		58.0 Kg.



Cubicle Load Break Switch



Dimensional Details 3P:

Load Break Switch 63A To 100A

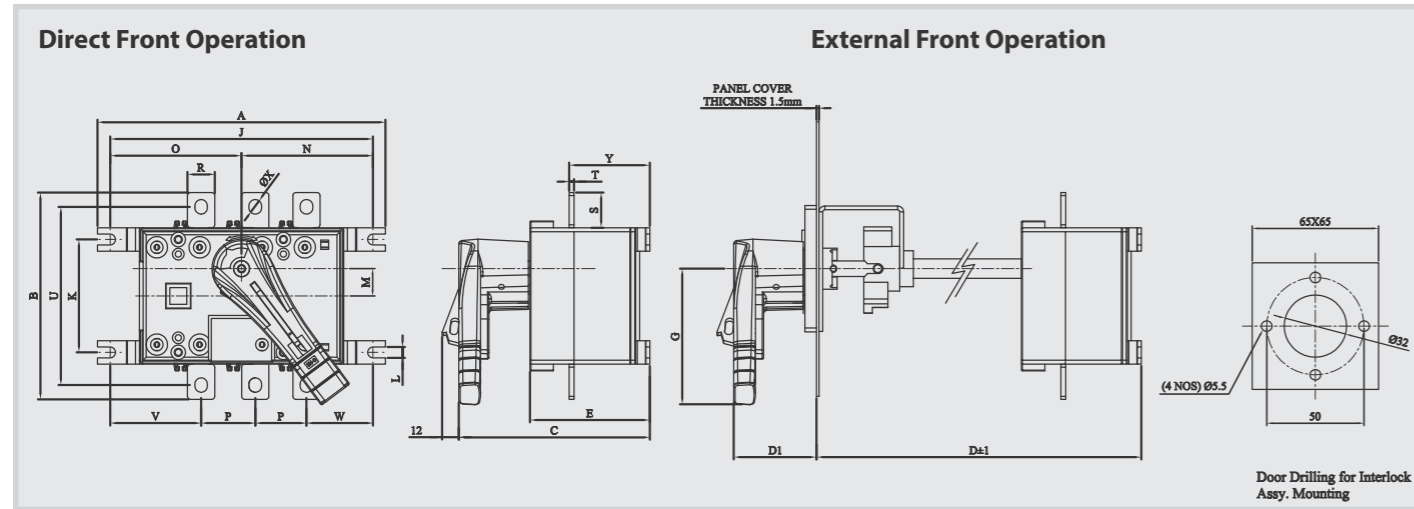

Over All Dimension		Fixing of SW.					Connection Terminal										SW. W.T.						
Rating	A	B	C	D	D1	E	G	J	K	L	M	N	O	P	R	S	T	U	V	W	ØX	Y	Open Ex.
3x63A	148	106	98	126	45	62	80	135	58	5.5	14	67.5	67.5	27	14	18	2.5	91	47.5	34	6.5	42	0.95 Kg.
3x80A	148	106	98	126	45	62	80	135	58	5.5	14	67.5	67.5	27	14	18	2.5	91	47.5	34	6.5	42	0.95 Kg.
3x100A	148	106	98	126	45	62	80	135	58	5.5	14	67.5	67.5	27	15	18	2.5	91	47.5	34	6.5	42	0.95 Kg.

Load Break Switch 125A To 630A

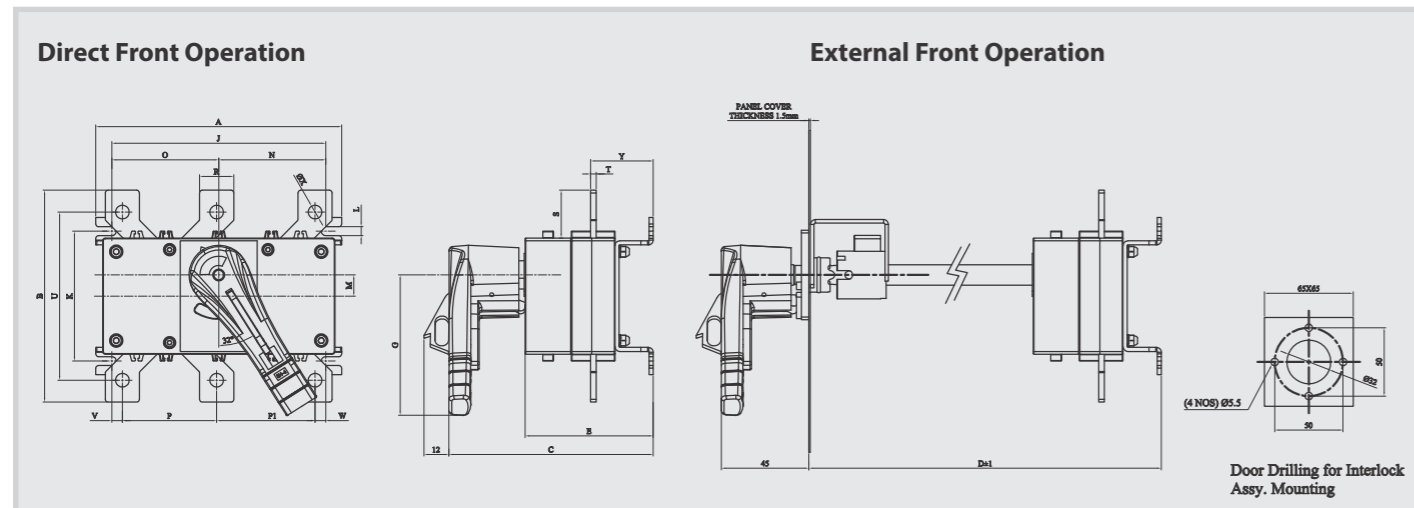

Over All Dimension		Fixing of SW.					Connection Terminal										SW. W.T.						
Rating	A	B	C	D	E	G	J	K	L	M	N	O	P	P1	R	S	T	U	V	W	ØX	Y	Open Ex.
3x125A	180	141	150	164	94	116	162	95	6.5	15	81	81	69	72	22	28	3	118	15	15	8.5	46	1.6 Kg
3x160A	180	155	150	164	94	116	162	95	6.5	15	81	81	69	72	25	35	4	123	10.5	10.5	10	46	2 Kg
3x200A	180	155	150	164	94	116	162	95	6.5	15	81	81	69	72	25	35	4	123	10.5	10.5	10	46	2 Kg
3x250A	240	192	160	176	104	150	217	111	6.5	20	109	109	93	100	32	46	4.5	152	15	9.5	12.5	48	2.9 Kg
3x320A	240	192	160	176	104	150	217	111	6.5	20	109	109	93	100	32	46	4.5	152	15	9.5	12.5	48	2.9 Kg
3x400A	304	240	200	192	144	150	280	180	9	30	140	140	110	130	40	40	5	206	30	30	11	69	5.6 Kg
3x630A	304	270	200	192	144	150	280	180	9	30	140	140	110	130	55	55	5	230	20	20	14.5	69	6.5 Kg



Cubicle Load Break Switch



Dimensional Details 3P:

Load Break Switch 800A To 1600A

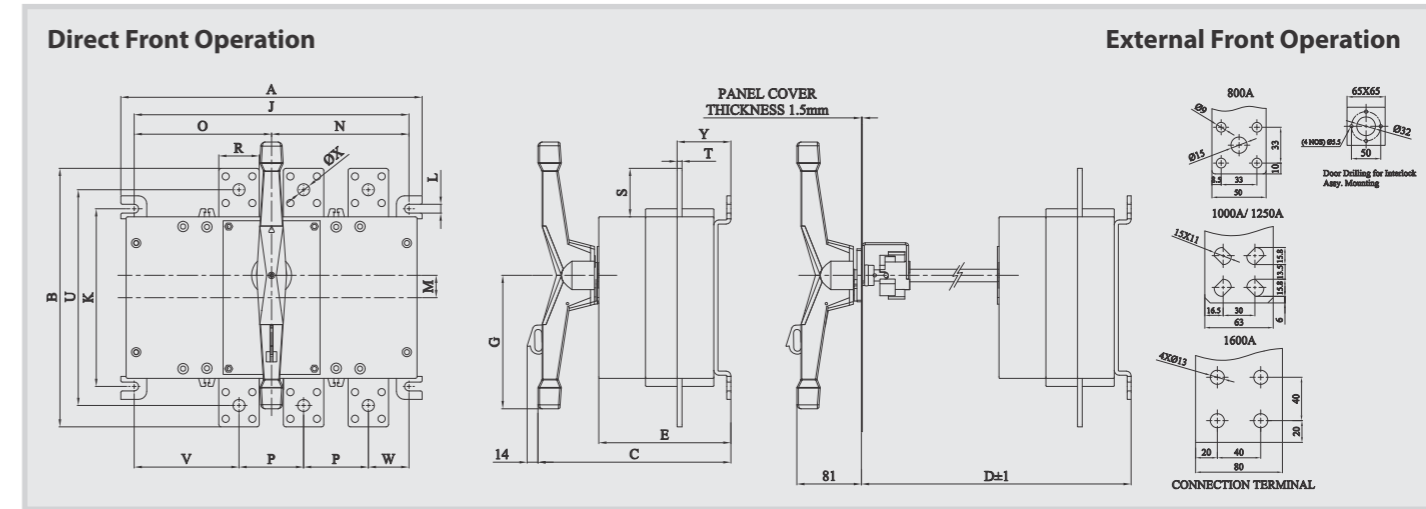

Over All Dimension		Fixing of SW.					Connection Terminal										SW. W.T.					
Rating	A	B	C	D	E	G	J	K	L	M	N	O	P	R	S	T	U	V	W	ØX	Y	Open Ex.
3x800A	373	320	235	234	164	165	340	220	11	28	170	170	80	50	60	6	267	130	50	15	67	10.9Kg
3x1000A	505	330	235	234	164	165	474	220	11	28	237	237	120	63	65	6	273	182	63	--	65	15.5Kg
3x1250A	505	330	235	234	164	165	474	220	11	28	237	237	120	63	65	7	273	182	63	--	66	15.7Kg
3x1600A	505	361	235	234	164	165	374	220	11	28	237	237	120	80	80	15	281	182	63	--	70	21.5Kg

Load Break Switch 2000A To 3150A

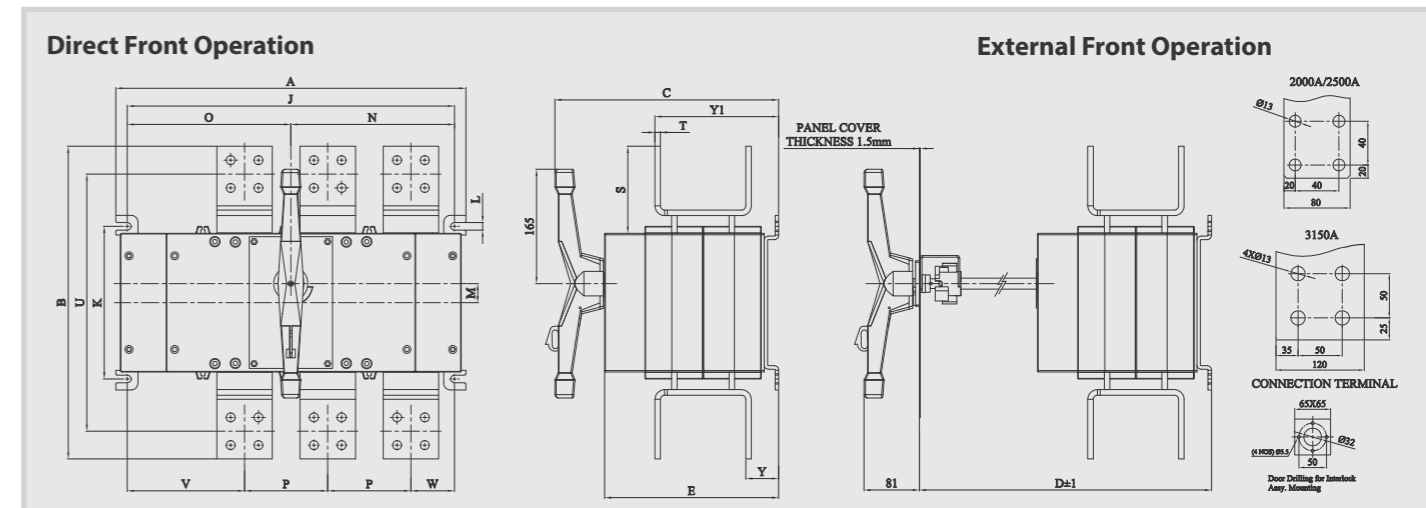

Over All Dimension		Fixing of SW.					Connection Terminal										SW. W.T.		
Rating	A	B	C	D	E	J	K	M	N	O	P	S	T	U	V	W	Y	Y1	Open Ex.
3x2000A	505	450	323	335	251	474	220	28	237	237	120	125	8	371	182	64	72	155	37.0 Kg.
3x2500A	505	450	323	335	251	474	220	28	237	237	120	125	10	371	182	64	73	156	38 Kg.
3x3150A	505	500	323	335	251	474	220	28	237	237	120	150	15	401	182	64	75	159	55.5 Kg.



Cubicle Load Break Switch



Load Break Switch Enclosed



LBS 630A

Function

- On load Making & Breaking current
- Emergency breaking
- Safe isolation of downstream loads for maintenance purpose

General Characteristics

- Black Handle padlockable in I-O position
- CRCA Sheet (Door 1.2 mm & Body 1.6mm)... 63A to 800A
- CRCA Sheet (Door 1.6mm & Body 2.0mm)... 1000A to 3150A
- Colour - Light Grey
- 2 External earthing points on each side
- Wall mounted with 4 bolts
- Door locking system allows opening of door only in OFF position
- Incoming & outgoing easily interchangeable at site
- Coating of epoxy polyester powder 70 micron
- Removable plate top & bottom
- Door with solid hinges

References and Dimensions

Rating	L	W	H	X	Y
63A-100A	180	255	141	215	210
125A-200A	260	365	186	325	290
250A-320A	345	455	196	416	380
400A-630A	395	575	217	515	450
800A	500	670	265	620	550
1000A-1600A	630	700	265	635	680
2000A-3150A	630	750	365	685	680

Note: All dimensions in mm

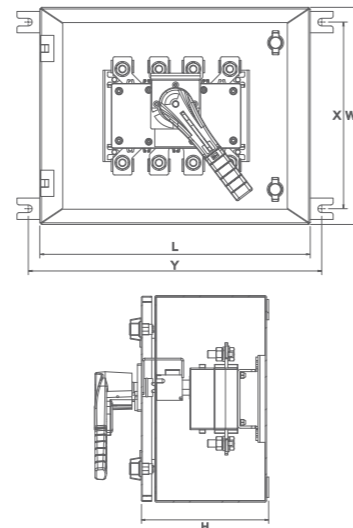

Cubicle Load Break Switch



Other Product Range

ATS

- Range 125A-630A, 4P, AC 23A, 3 frame sizes
- Trip Safety as standard feature, CE marked, RoHS Compliant
- Power monitoring- kWh, kVAh, kVA, kVArh
- User selectable Rs232 & RS485 communications
- Configurable over riding voltage parameters
- Programable source priority



ACB

- Range : 630A – 6300A
- Operational voltage 690V & above
- Icu 50kA to 120kA at 500Vac
- Ics = 100% Icu throughout the range
- Icw : 50kA to 100kA (for 1 sec)
- Customer oriented Trip Relay - with advanced measurement functions & communication functions



Microprocessor MCCB

- Microprocessor range from 250A - 800A, Icu 36kA to 65kA.
- Adjustable overload, short circuit and ground fault with variable time setting and suitable for discrimination.
- Icu 36kA to 65kA, 3P & 4P (4PNutral fully protected). fixed and adjustable trip settings.



Controlgear

- Widest Range of 3P & 4P Contactors upto 800A.
- Capacitor Duty Contactors upto 62 kvar.
- Highest Electrical Life upto 2.5 million operations.
- Site mounted add on accessories (Auxiliary Contacts, Mechanical Interlock, Surge Suppressor, Timer, Mechanical Latch Units).
- Conformity to latest IEC/IS Standards.
- Type II Co-ordination. CE marked & UL Certified.

